

SYM.	DATE	ECN	SIG.	DESCRIPTION	ENG.
A	1/25/19		DMM	ROUNDED DIMS.	DMM
B	3/20/19		DMM	ADDED SIZE 142	DMM

AX-4700 AND AX-4300 SIZE 72 TO 142, 0.45 HUB RATIO, ARRANGEMENT 3 WITH DIFFUSER

**SB-117**  
**07.20.250.R0**

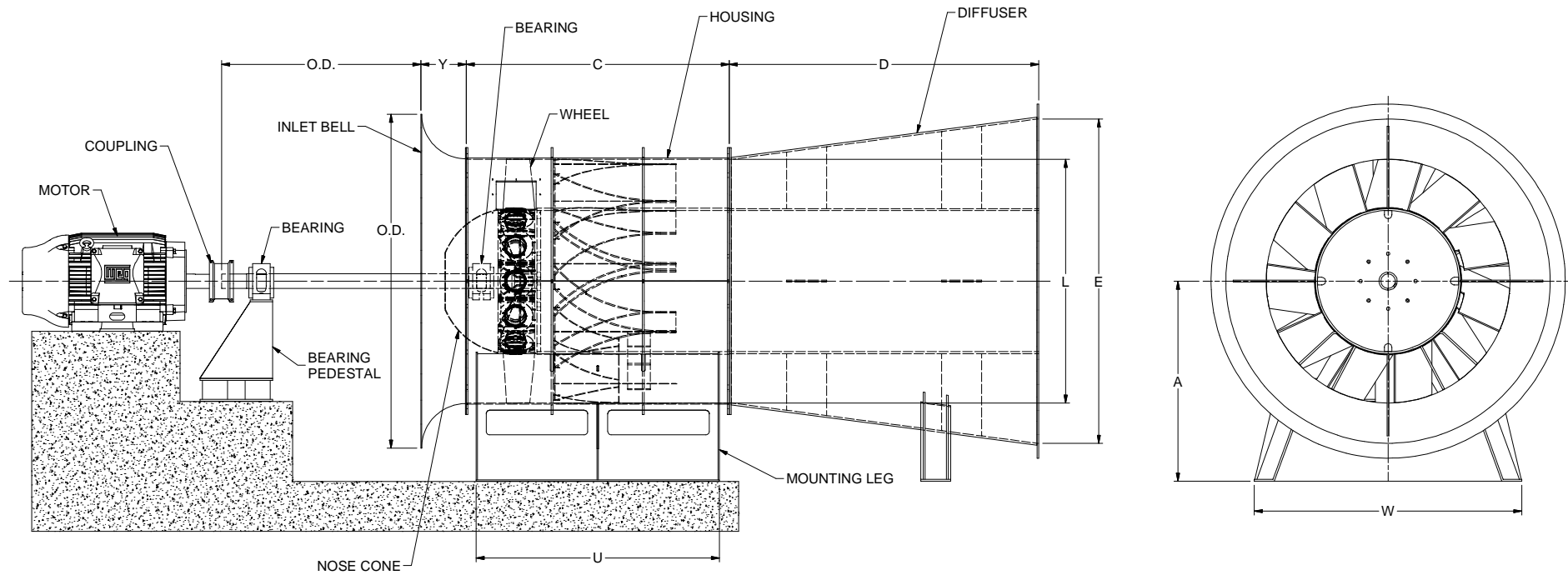

UNITS IN inches [mm]

SIZE	OD	Y	C	D	L	E	A	U	W	WEIGHT (FAN NOT INCLUDING MOTOR) lbs (kgs)
72-18	96 [2440]	18 [455]	60 [1525]	90 [2285]	72 [1830]	96 [2440]	54 [1370]	48 [1220]	78 [1980]	9,650 (4,400)
84-21	110 [2795]	22 [560]	70 [1780]	98 [2490]	84 [2135]	108 [2745]	60 [1525]	56 [1420]	90 [2285]	12,500 (5,700)
96-24	126 [3200]	24 [610]	80 [2030]	114 [2895]	96 [2440]	120 [3050]	66 [1675]	64 [1625]	104 [2640]	15,000 (6,800)
108-27	144 [3655]	32 [815]	80 [2030]	136 [3455]	108 [2745]	144 [3655]	78 [1980]	64 [1625]	116 [2945]	19,000 (8,600)
120-30	156 [3960]	36 [915]	90 [2290]	144 [3655]	120 [3050]	156 [3960]	84 [2135]	72 [1830]	128 [3250]	21,500 (9,700)
132-33	171 [4345]	42 [1065]	96 [2440]	158 [4015]	132 [3350]	171 [4345]	90 [2285]	78 [1980]	140 [3555]	25,000 (11,500)
142-36	184 [4674]	48 [1219]	108 [2743]	178 [4545]	142 [3600]	184 [4674]	92 [2336]	88 [2235]	154 [3911]	36,000 (16,500)

GENERAL NOTES:  
1. UNLESS OTHERWISE SPECIFIED ALL DIMENSIONS ARE IN INCHES.  
2. ALL FORMS ARE UP, UNLESS OTHERWISE SPECIFIED.  
3. DIMENSIONS IN ( ) ARE FOR REFERENCE ONLY.

NOTICE: This drawing is the property of THE NEW YORK BLOWER COMPANY CO. and is loaned subject to the condition that it shall not be reproduced, copied, loaned or submitted to outside parties without our consent.



**THE NEW YORK  
BLOWER COMPANY**

DESCRIPTION:  
AX-4700 AND AX-4300 SIZE 72 TO 142, 0.45 HUB RATIO, ARR 4 WITH DIFFUSER

FILE NUMBER: \_\_\_\_\_  
SEQUENCE: \_\_\_\_\_  
DRAWN BY: LW  
DRAWN DATE: 3/27/2018  
ENGINEER: \_\_\_\_\_  
SCALE: \_\_\_\_\_

THE NEW YORK BLOWER COMPANY  
1769 Quincy Street  
Wilmette, IL 60097-9530  
Visit us on the Web: <http://www.nyb.com>  
Phone: (800) 208-7918 Email: [nyb@nyb.com](mailto:nyb@nyb.com)

PART NUMBER  
**SB-117**

DWG. SIZE: \_\_\_\_\_  
MATERIAL: \_\_\_\_\_  
TOL: ± 1/8 MASS: N/A

REV. \_\_\_\_\_