

FRP RADIAL FUME EXHAUSTERS/ PRESSURE BLOWERS

Fiberglass-reinforced-plastic fans for handling corrosive gas streams in a wide variety of process applications...

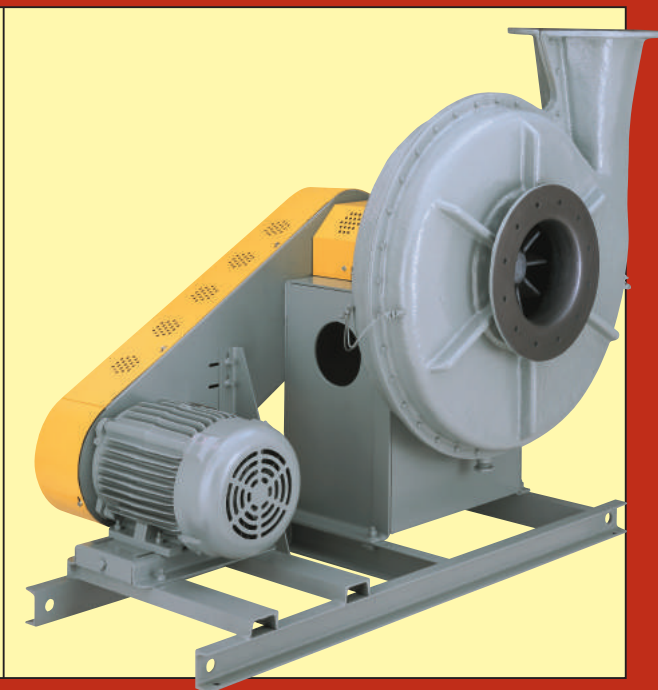

FRP RADIAL FUME EXHAUSTERS

- Static pressures to 14"WG
- Capacities to 7,500 CFM
- Temperatures to 250°F.

FRP PRESSURE BLOWERS

- Static pressures to 36"WG
- Capacities to 5,000 CFM
- Temperatures to 250°F.



THE NEW YORK BLOWER COMPANY®

7660 QUINCY STREET—WILLOWBROOK, ILLINOIS 60527-5530
PHONE: [630] 794-5700 • FAX: [630] 794-5776 • E-MAIL: nyb@nyb.com

Visit us on the Web: <http://www.nyb.com>

FRP RADIAL FUME EXHAUSTERS

DESIGN FEATURES

The New York Blower Company's FRP Radial Fume Exhauster [RFE] and FRP Pressure Blower [FPB] are designed so that all parts exposed to the airstream are constructed of high-quality corrosion-resistant fiberglass reinforced plastic. The RFE and FPB are resistant to attack from most chemicals and are ideally suited to applications in the chemical, pulp and paper, wastewater-treatment, fertilizer, pharmaceutical, and metal-plating industries.

Specifically, the RFE is designed for exhausting moderate volumes of highly corrosive fumes at moderate pressures. Typical applications include laboratory fume hoods, small plating and pickling operations, etching processes, and chemical-fume scrubbers. The FPB is designed for low volumes at high pressures. Typical applications include pulp and paper processes, chemical-fume scrubbers, and soil remediation.

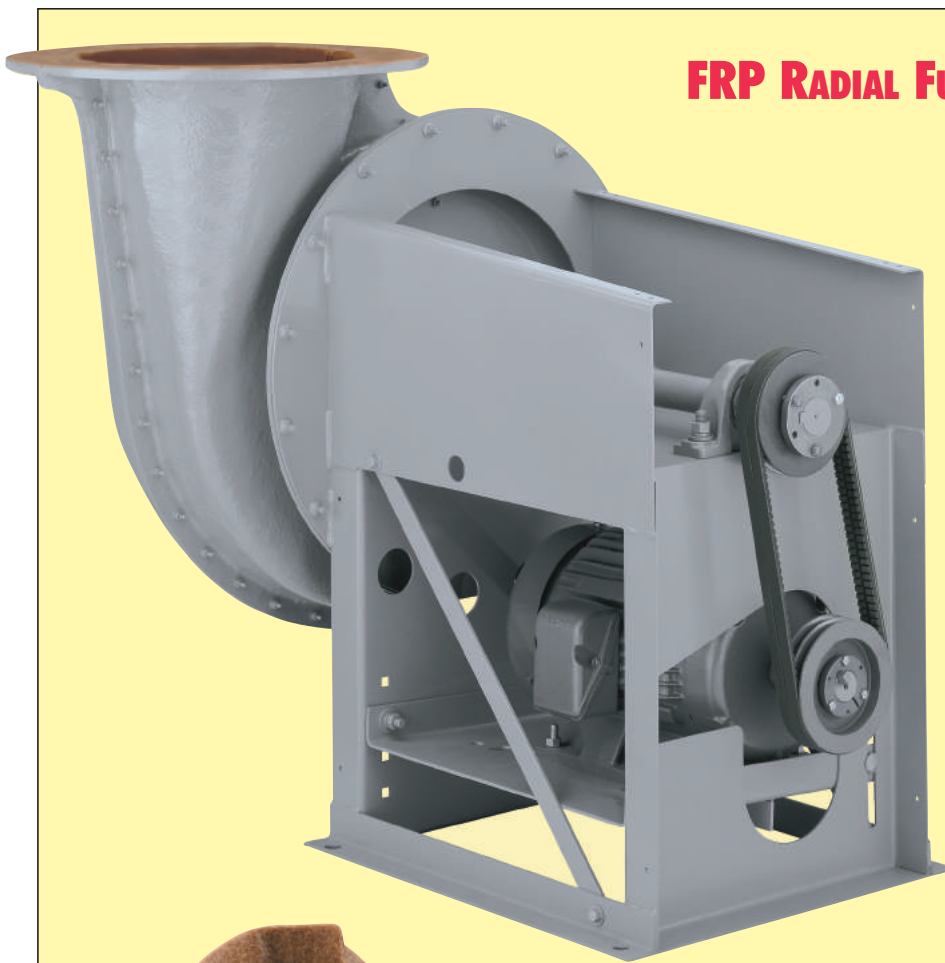

FRP RADIAL FUME EXHAUSTERS

- Five sizes: 160, 200, 315, 400, and 500 mm inlet-duct diameters [8", 10", 14", 18", and 22" wheel diameters].
- Capacities to 7,500 CFM.
- Static pressures to 14"WG.
- Temperatures to 250°F.
- Available in compact Arrangement 10 design.

RFE-400, Arrangement 10, clockwise Up Blast, with optional motor and v-belt drive.

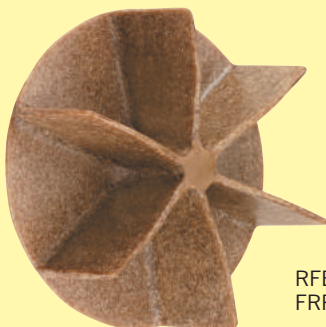

RFE radial FRP wheel.



AMCA SEAL
The New York Blower Company certifies that the Radial Fume Exhausters shown herein are licensed to bear the AMCA Seal. The ratings shown on pages 6 and 7 are based on tests and procedures performed in accordance with AMCA Publication 211 and comply with the requirements of the AMCA Certified Ratings Program.

AND PRESSURE BLOWERS

CONSTRUCTION FEATURES

- Wheel is cast in a one-piece mold with a resin-glass mixture featuring premium-quality, corrosion-resistant vinyl ester resin. Solid FRP wheels are oven-cured to provide optimum strength and corrosion resistance. Radial-blade design provides stable, pulsation-free performance over the entire pressure range from wide-open to closed-off.
- Standard shaft is ASTM A-108 steel, grade C-1040/1045. Inside the fan housing the shaft is covered with an FRP sleeve that is bonded to the wheel backplate and extends through the housing side, protecting the shaft from corrosive attack . . . 316 SST shafting also available.
- Housing is made of premium-quality, corrosion-resistant vinyl ester resin. The interior is extremely smooth, due to fabrication on male molds.
- Flanged inlet and outlet for easy in-duct connection; supplied without holes as standard. Flange drilling available in choice of National Bureau of Standards Voluntary Product Standard PS15-69 or ANSI Class 150 lb. patterns.
- All fans are rotatable to any of six discharge positions.
- Lifting eyes on all fans for ease of handling.
- Welded-steel base is constructed of heavy-gauge components for structural strength and durability. Arrangement 10 base features self-contained motor platform.
- Close-fitting, Teflon® shaft-hole closure limits the free exchange of gases through the shaft-hole opening.
[Teflon is a registered trademark of DuPont.]
- Neoprene gasketing at all bolted FRP joints.
- Fan exterior is coated with gray epoxy enamel.
- RFE and FPB wheels are dynamically balanced before final assembly. After assembly, all fans are given a final balance check at the specified running speed.
- Meets ASTM D 4167 Standard Specification for Fiber-Reinforced Plastic Fans and Blowers when fan is purchased with surface veil.

SPECIAL ALLOY WHEEL AND SHAFT ASSEMBLIES—

316 stainless steel and Hastelloy® C-276 alloy wheel and shaft assemblies are available for applications where high moisture content may cause erosion of the standard FRP wheel. Available on Arrangement 1 and 8 FRP Pressure Blowers only. Consult your New York Blower sales representative for details and pricing.

[®Hastelloy is a registered trademark of Haynes International, Inc.]

FRP PRESSURE BLOWERS

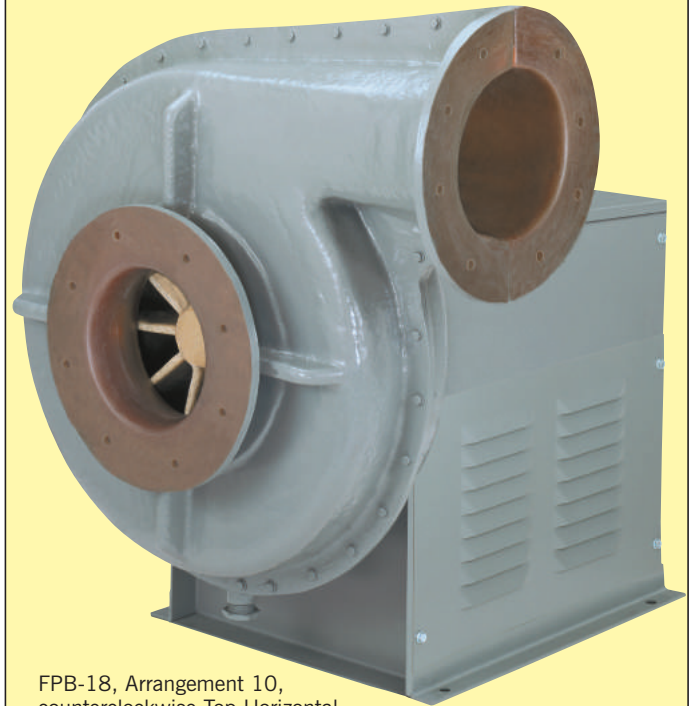

FPB-18, Arrangement 10, counterclockwise Top Horizontal, with optional flange drilling, drain, and weather cover/belt guard.

- Three sizes: 18", 22", and 28" wheel diameters.
- Capacities to 5,000 CFM.
- Static pressures to 36" WG.
- Temperatures to 250°F.
- Choice of Arrangements: 1, 8, or 10.
- Choice of fiberglass or alloy wheel construction.

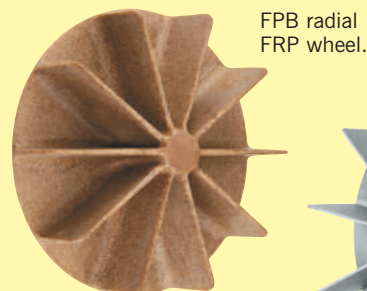

FPB radial FRP wheel.

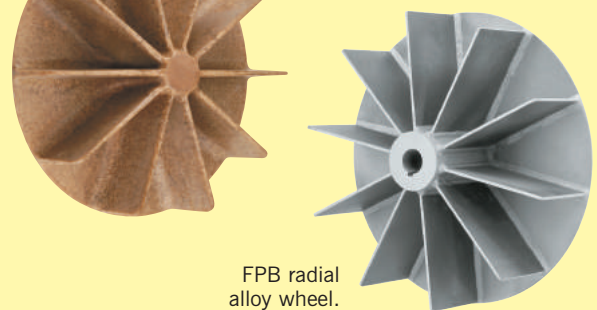

FPB radial alloy wheel.

ACCESSORIES/MODIFICATIONS

- **Shaft seal**—Viton® elements in FRP casing. Type 316 SST sleeve covers shaft for use with seal. Optional Teflon seal and Hastelloy C-276 sleeve available. [Viton is a registered trademark of DuPont Dow Elastomers.]
- **Outlet damper**—corrosion-resistant FRP wafer-type damper sized to match FRP fan outlet flange. Damper flanges drilled as standard.
- **Companion flange with collar**—FRP construction; used on inlet or outlet to provide a slip connection for customer-furnished flexible connection.
- **Flanged drilling**—for ease of direct connection; dimensions shown on page 10.
- **Unitary base**—available with spring or rubber-in-shear [R-I-S] isolators. Isolation rails are available for Arrangement 10 fans.
- **Drain**—threaded FRP drain with PVC plug, 1" npt, at lowest point of housing scroll.
- **Inspection port**—allows examination of fan interior. Located on inlet side half of housing at 2 or 10 o'clock, opposite discharge. Port size is 3" on RFE-160/200/315, and FPB-18/22; and 4" on RFE-400/500, and FPB-28.
- **Surface veil**—for added protection against certain corrosives. Provides compliance with ASTM D 4167.
- **Graphite impregnation**—to control static electricity. The gas-stream surfaces are grounded to the fan base.
- **Positive screw adjustment**—two threaded rods provide easy motor platform/V-belt adjustment. [Arrangement 10 fans only.]
- **Arrangement 10 weather cover/belt guard**—provides motor and drive protection, and can be easily removed for inspection and maintenance. Louvered side panels provide ample motor ventilation.
- **Safety equipment**—belt guards and shaft and bearing guards are available for Arrangement 1 fans, and coupling guards for Arrangement 8 fans. Extended lube lines are furnished as standard with shaft and bearing guard.
- **Drive components**—a wide variety of motors, couplings, and v-belt drives are available from **nyb**.



FPB-22, Arrangement 8, clockwise Up Blast, with optional flange drilling, drain, inspection port, wafer-type outlet damper, motor, coupling, and guards.

RFE-315, Arrangement 10, counterclockwise Top Horizontal, with optional flange drilling, drain, graphite impregnation, and weather cover/belt guard.

FPB-22, Arrangement 1, clockwise Up Blast, with optional flange drilling, drain, graphite impregnation, unitary base, motor, v-belt drive, and guards.

SAFETY EQUIPMENT

Safety accessories are available from **nyb**, but selection of the appropriate devices is the responsibility of the system-designer who is familiar with the particular installation, or application, and can provide for guards for all exposed moving parts as well as protection from access to high-velocity airstreams. Neither **nyb** nor its sales representatives is in a position to make such a determination. Users and/or installers should read "Recommended Safety Practices for Air Moving Devices" as published by the Air Movement and Control Association International, Arlington Heights, Illinois.

How to Use Performance Tables

For a given fan size, CFM, and static pressure, capacity tables can be used to obtain outlet velocity, wheel RPM, and BHP. If capacities are at conditions other than 70°F., sea level, or standard density [.075 lbs./cu.ft.], correction factors must be applied to static pressure and BHP.

STEPS TO FOLLOW	STEPS	EXAMPLE: Size RFE-400 fan to handle 2400 CFM at 8"WG at 200°F. at sea level.
Determine fan static pressure at standard conditions. If temperature or altitude is involved, correct for air density [see Charts I and II].	1	Chart I shows 1.25 correction factor for 200°F. 8"WG x 1.25 = 10"WG at 70°F.
Select size, RPM, and BHP of fan from capacity tables.	2	Capacity table shows 2659 RPM, 7.9 BHP for Size RFE-400 fan at 2400 CFM at 10"WG at 70°F.
Check the maximum safe speed of the fan shown below in Chart III.	3	Maximum safe speed of Size RFE-400 fan is 3050 RPM at 70°F.
Apply temperature maximum safe speed factors from Chart IV to maximum safe speed of fan from Step 3 to determine new maximum safe speed when temperature is involved.	4	Chart IV shows .94 correction factor for 200°F. .94 x 3050 RPM = 2867 RPM at 200°F.
Determine actual performance by dividing static pressure and BHP* from Step 2 by the correction factor in Step 1.	5	Actual performance: 2400 CFM at 8"WG at 2659 RPM at 6.32 BHP at 200°F.

*NOTE: Motor should be selected for BHP @ 70°F. to insure proper operation during "cold starts."

CHART I CORRECTION FACTORS FOR TEMPERATURE [°F.]	
Temperature	Factor
-50	.77
-25	.82
0	.87
20	.91
40	.94
70	1.00
100	1.06
130	1.11
160	1.17
200	1.25
250	1.34

CHART II CORRECTION FACTORS FOR ALTITUDE [feet above sea level]	
Altitude	Factor
0	1.00
1000	1.04
2000	1.08
3000	1.12
4000	1.16
5000	1.20
6000	1.25
7000	1.30
8000	1.35
9000	1.40
10000	1.45

CHART III MAXIMUM SAFE WHEEL SPEED AT 70°F.	
Size	RPM
RFE-160	4800
RFE-200	4800
RFE-315	3760
RFE-400	3050
RFE-500	2440
FPB-18	4000
FPB-22	3600
FPB-28	2500

CHART IV SAFE SPEED CORRECTION FACTORS FOR TEMP. [°F.]	
Temperature	Factor
70-150	1.0
200	.94
225	.86
250	.73

Note: 250°F. is maximum allowable temperature.

NOTE: If correction factor for both temperature and altitude is required, multiply factors from Chart I and II together: 3000 and 200°F. 1.12 x 1.25 = 1.40 [combined factor].

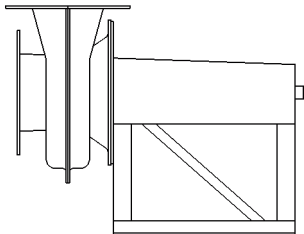
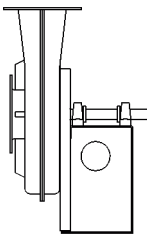
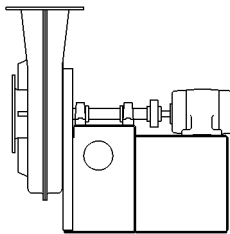
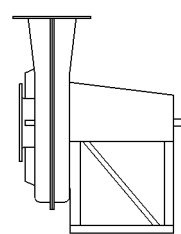
FAN ARRANGEMENTS			
FRP RADIAL FUME EXHAUSTERS	FRP PRESSURE BLOWERS		
			
ARRANGEMENT 10	ARRANGEMENT 1	ARRANGEMENT 8	ARRANGEMENT 10

PERFORMANCE FOR FRP RADIAL FUME EXHAUSTERS

SIZE 160				Wheel diameter: 8" Wheel circumference: 2.09'				Inlet diameter: 6" I.D. Fan outlet area = .216 sq. ft.				Maximum BHP = $.017 \left[\frac{\text{RPM}}{1000} \right]^3$									
CFM	OV	1"SP		2"SP		3"SP		4"SP		4½"SP		5"SP		5½"SP		6"SP		6½"SP		7"SP	
		RPM	BHP	RPM	BHP	RPM	BHP	RPM	BHP	RPM	BHP	RPM	BHP	RPM	BHP	RPM	BHP	RPM	BHP	RPM	BHP
40	185	1763	0.1	2484	0.1	3052	0.3	3514	0.4	3735	0.4	3927	0.5	4124	0.6	4307	0.7	4488	0.8	4664	0.9
80	370	1795	0.1	2504	0.2	3059	0.3	3533	0.4	3734	0.5	3931	0.6	4135	0.7	4310	0.7	4483	0.8	4651	0.9
120	556	1858	0.1	2549	0.2	3087	0.3	3549	0.5	3762	0.6	3966	0.6	4154	0.7	4339	0.8	4495	0.9	4662	1.0
160	741	1967	0.1	2610	0.2	3136	0.4	3585	0.5	3795	0.6	3992	0.7	4182	0.8	4361	0.9	4538	1.0	4694	1.1
200	926	2101	0.1	2706	0.3	3211	0.4	3646	0.6	3854	0.7	4047	0.8	4216	0.9	4400	1.0	4574	1.1	4735	1.2
240	1111	2257	0.2	2824	0.3	3296	0.5	3728	0.7	3913	0.7	4101	0.9	4291	1.0	4459	1.1	4620	1.2	4793	1.3
280	1296	2433	0.2	2964	0.4	3411	0.5	3824	0.7	4005	0.8	4191	0.9	4365	1.1	4537	1.2	4688	1.3		
320	1481	2621	0.3	3116	0.4	3539	0.6	3928	0.8	4107	0.9	4291	1.0	4452	1.2	4627	1.3	4770	1.4		
360	1667	2813	0.4	3284	0.5	3692	0.7	4058	0.9	4235	1.0	4397	1.2	4571	1.3	4724	1.4				
400	1852	3015	0.4	3463	0.6	3852	0.8	4206	1.1	4374	1.2	4536	1.3	4692	1.4						
440	2037	3228	0.5	3645	0.8	4016	1.0	4352	1.2	4519	1.3	4665	1.4								
480	2222	3440	0.7	3840	0.9	4197	1.1	4518	1.4	4669	1.5										
520	2407	3659	0.8	4038	1.0	4379	1.3	4684	1.6												
560	2593	3879	1.0	4238	1.2	4562	1.5														
600	2778	4105	1.1	4447	1.4	4761	1.7														
640	2963	4330	1.3	4655	1.6																

SIZE 200				Wheel diameter: 10" Wheel circumference: 2.62'				Inlet diameter: 8" I.D. Fan outlet area = .338 sq. ft.				Maximum BHP = $.037 \left[\frac{\text{RPM}}{1000} \right]^3$									
CFM	OV	1"SP		3"SP		4"SP		5"SP		6"SP		7"SP		8"SP		9"SP		10"SP		11"SP	
		RPM	BHP	RPM	BHP	RPM	BHP	RPM	BHP	RPM	BHP	RPM	BHP	RPM	BHP	RPM	BHP	RPM	BHP	RPM	BHP
140	414	1446	0.1	2468	0.3	2845	0.4	3177	0.5	3473	0.6	3758	0.8	4013	1.0	4269	1.1	4498	1.3	4708	1.5
220	651	1524	0.1	2496	0.3	2857	0.4	3187	0.6	3496	0.7	3766	0.9	4021	1.1	4270	1.3	4502	1.5	4706	1.6
300	888	1647	0.1	2551	0.4	2913	0.5	3230	0.7	3516	0.8	3785	1.0	4042	1.2	4290	1.4	4501	1.6	4734	1.8
380	1124	1812	0.2	2635	0.5	2981	0.6	3290	0.8	3571	1.0	3830	1.2	4086	1.4	4319	1.6	4542	1.8	4745	2.0
460	1361	2000	0.3	2752	0.6	3067	0.7	3373	0.9	3638	1.1	3889	1.3	4142	1.6	4374	1.8	4591	2.0		
540	1598	2206	0.3	2891	0.7	3189	0.9	3469	1.1	3735	1.3	3981	1.5	4206	1.8	4442	2.0	4655	2.3		
620	1834	2423	0.5	3054	0.9	3329	1.1	3592	1.3	3842	1.5	4074	1.7	4300	2.0	4527	2.3	4720	2.5		
700	2071	2650	0.6	3231	1.0	3491	1.3	3742	1.5	3965	1.7	4196	2.0	4414	2.3	4621	2.5				
780	2308	2878	0.8	3423	1.3	3664	1.5	3893	1.8	4122	2.0	4330	2.3	4540	2.6	4732	2.8				
860	2544	3111	1.0	3627	1.5	3852	1.8	4076	2.1	4285	2.3	4487	2.6	4675	2.9						
940	2781	3346	1.3	3838	1.8	4053	2.1	4260	2.4	4451	2.7	4647	3.0								
1020	3018	3585	1.6	4050	2.2	4255	2.5	4456	2.8	4642	3.1										
1100	3254	3822	1.9	4271	2.6	4466	2.9	4655	3.2												
1180	3491	4063	2.3	4495	3.0	4681	3.4														
1260	3728	4306	2.8	4722	3.5																
1340	3964	4549	3.3																		

SIZE 315				Wheel diameter: 14" Wheel circumference: 3.67'				Inlet diameter: 12" I.D. Fan outlet area = .839 sq. ft.				Maximum BHP = $.189 \left[\frac{\text{RPM}}{1000} \right]^3$									
CFM	OV	1"SP		3"SP		5"SP		7"SP		8"SP		9"SP		10"SP		11"SP		12"SP		13"SP	
		RPM	BHP	RPM	BHP	RPM	BHP	RPM	BHP	RPM	BHP	RPM	BHP	RPM	BHP	RPM	BHP	RPM	BHP	RPM	BHP
700	834	1233	0.3	1842	0.7	2300	1.2	2703	1.8	2871	2.1	3041	2.4	3210	2.8	3349	3.1	3501	3.5	3639	3.8
840	1001	1336	0.4	1905	0.9	2351	1.4	2733	2.1	2899	2.4	3070	2.7	3226	3.1	3378	3.5	3524	3.9	3659	4.2
980	1168	1448	0.5	1981	1.0	2410	1.7	2780	2.3	2946	2.7	3106	3.1	3252	3.4	3397	3.8	3545	4.3	3688	4.7
1120	1335	1569	0.6	2067	1.2	2476	1.9	2829	2.6	2995	3.0	3146	3.4	3299	3.8	3438	4.3	3574	4.7	3722	5.2
1260	1502	1694	0.8	2167	1.5	2560	2.2	2897	3.0	3056	3.4	3200	3.8	3347	4.2	3496	4.7	3630	5.2	3760	5.6
1400	1669	1822	1.0	2271	1.7	2646	2.5	2971	3.3	3125	3.8	3265	4.2	3408	4.7	3541	5.2	3685	5.7		
1540	1836	1957	1.3	2379	2.0	2735	2.9	3051	3.8	3201	4.2	3347	4.7	3479	5.2	3610	5.7	3741	6.2		
1680	2002	2095	1.6	2492	2.4	2833	3.3	3136	4.2	3283	4.7	3427	5.2	3557	5.8	3678	6.2				
1820	2169	2234	2.0	2609	2.8	2939	3.8	3233	4.7	3370	5.3	3504	5.8	3633	6.3						
1960	2336	2376	2.4	2732	3.3	3052	4.3	3338	5.3	3469	5.9	3595	6.4	3723	7.0						
2100	2503	2520	2.8	2857	3.8	3162	4.9	3441	6.0	3565	6.5	3698	7.1								
2240	2670	2665	3.4	2987	4.4	3279	5.5	3542	6.7	3671	7.3										
2380	2837	2812	4.0	3115	5.1	3399	6.3	3656	7.5												
2520	3004	2959	4.6	3249	5.8	3516	7.0														
2660	3170	3107	5.4	3382	6.6	3641	7.9														
2800	3337	3256	6.2	3520	7.5																



Performance shown is installation Type B: Free inlet, Ducted outlet. Power rating (BHP) does not include drive losses. Performance ratings do not include the effects of appurtenances in the airstream.

PERFORMANCE FOR FRP RADIAL FUME EXHAUSTERS

CFM		OV		1"SP		3"SP		5"SP		7"SP		8"SP		9"SP		10"SP		11"SP		12"SP		13"SP	
				RPM	BHP	RPM	BHP	RPM	BHP	RPM	BHP	RPM	BHP	RPM	BHP	RPM	BHP	RPM	BHP	RPM	BHP	RPM	BHP
				Wheel diameter: 18" Wheel circumference: 4.71' Inlet diameter: 16" I.D. Fan outlet area = 1.35 sq. ft. Maximum BHP = .631 $\left[\frac{\text{RPM}}{1000} \right]^3$																			
1200	889	976	0.5	1430	1.2	1781	2.0	2078	2.8	2217	3.3	2339	3.8	2458	4.3	2581	4.8	2686	5.3	2800	5.9		
1400	1037	1047	0.6	1477	1.4	1820	2.3	2105	3.2	2236	3.7	2358	4.2	2480	4.8	2600	5.3	2697	5.8	2802	6.4		
1600	1185	1125	0.8	1534	1.6	1857	2.6	2141	3.7	2267	4.2	2385	4.7	2504	5.3	2622	5.9	2721	6.5	2828	7.1		
1800	1333	1208	1.0	1594	1.9	1911	3.0	2177	4.1	2308	4.7	2424	5.3	2541	5.9	2646	6.5	2747	7.1	2855	7.8		
2000	1481	1292	1.2	1662	2.3	1961	3.4	2227	4.6	2347	5.2	2462	5.9	2568	6.5	2683	7.2	2786	7.8	2884	8.5		
2200	1630	1379	1.5	1730	2.6	2019	3.9	2275	5.1	2393	5.8	2507	6.5	2614	7.2	2720	7.9	2825	8.6	2914	9.3		
2400	1778	1468	1.8	1806	3.1	2085	4.4	2328	5.7	2446	6.4	2560	7.2	2659	7.9	2767	8.7	2863	9.4	2956	10.1		
2600	1926	1559	2.2	1882	3.5	2148	4.9	2391	6.4	2503	7.1	2610	7.9	2711	8.7	2812	9.5	2911	10.3	2997	11.0		
2800	2074	1652	2.6	1958	4.0	2223	5.6	2451	7.1	2564	7.9	2667	8.7	2762	9.5	2865	10.3	2957	11.2	3047	12.0		
3000	2222	1747	3.1	2040	4.6	2295	6.2	2516	7.8	2624	8.7	2728	9.6	2826	10.4	2916	11.2	3012	12.2				
3200	2370	1842	3.7	2123	5.3	2370	7.0	2589	8.7	2694	9.6	2787	10.4	2888	11.4	2973	12.2						
3400	2519	1938	4.3	2211	6.0	2447	7.8	2660	9.6	2761	10.5	2858	11.5	2948	12.4	3044	13.4						
3600	2667	2036	5.0	2298	6.8	2526	8.7	2730	10.5	2827	11.5	2920	12.5	3020	13.6								
3800	2815	2133	5.8	2382	7.7	2604	9.6	2808	11.6	2903	12.6	2993	13.6										
4000	2963	2231	6.7	2473	8.6	2689	10.7	2884	12.7	2977	13.8												
4200	3111	2330	7.6	2563	9.7	2772	11.8	2964	14.0														

CFM		OV		1"SP		3"SP		5"SP		7"SP		9"SP		10"SP		11"SP		12"SP		13"SP		14"SP	
				RPM	BHP	RPM	BHP	RPM	BHP	RPM	BHP	RPM	BHP	RPM	BHP	RPM	BHP	RPM	BHP	RPM	BHP	RPM	BHP
				Wheel diameter: 22" Wheel circumference: 5.76' Inlet diameter: 20" I.D. Fan outlet area = 2.11 sq. ft. Maximum BHP = 1.70 $\left[\frac{\text{RPM}}{1000} \right]^3$																			
1200	569	704	0.4	1114	1.1	1417	2.0	1669	2.9	1897	4.0	1999	4.6	2100	5.2	2185	5.8	2278	6.5	2365	7.1		
1600	758	762	0.5	1154	1.4	1440	2.4	1683	3.5	1903	4.8	2000	5.4	2098	6.0	2189	6.7	2276	7.4	2361	8.1		
2000	948	834	0.7	1204	1.7	1484	2.9	1711	4.2	1923	5.5	2018	6.2	2110	6.9	2203	7.7	2288	8.4	2371	9.2		
2400	1137	918	1.0	1261	2.2	1532	3.5	1754	4.9	1956	6.4	2051	7.2	2139	7.9	2223	8.7	2313	9.6	2396	10.5		
2800	1327	1007	1.4	1324	2.7	1590	4.2	1807	5.7	2005	7.3	2093	8.2	2179	9.0	2262	9.9	2340	10.8	2424	11.7		
3200	1517	1101	1.9	1395	3.3	1642	4.9	1862	6.6	2054	8.4	2141	9.3	2227	10.2	2310	11.2	2390	12.2				
3600	1706	1197	2.6	1472	4.1	1708	5.8	1918	7.6	2108	9.5	2194	10.5	2280	11.5	2356	12.5	2437	13.6				
4000	1896	1297	3.3	1558	5.0	1778	6.8	1976	8.7	2164	10.8	2251	11.9	2331	12.9	2416	14.1						
4400	2085	1399	4.2	1645	6.1	1853	8.0	2042	10.0	2225	12.2	2306	13.3	2386	14.5								
4800	2275	1504	5.3	1734	7.3	1931	9.3	2114	11.5	2288	13.8	2371	15.0										
5200	2464	1610	6.6	1826	8.7	2018	10.9	2187	13.1	2354	15.5	2433	16.8										
5600	2654	1717	8.0	1919	10.3	2106	12.7	2272	15.1	2428	17.6												
6000	2844	1826	9.7	2016	12.2	2195	14.7	2353	17.2														
6400	3033	1935	11.6	2114	14.2	2285	16.9																
6800	3223	2044	13.8	2213	16.5	2377	19.3																
7200	3412	2154	16.2	2315	19.1																		

Performance shown is installation Type B: Free inlet, Ducted outlet. Power rating (BHP) does not include drive losses. Performance ratings do not include the effects of appurtenances in the airstream.

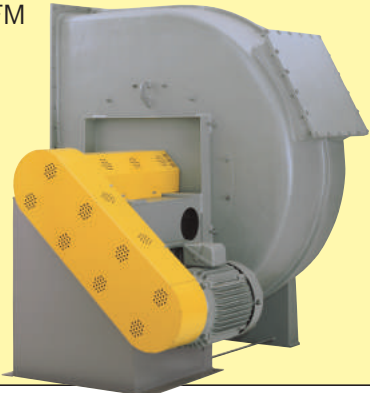
<p>OTHER</p>  <p>FRP PRODUCTS</p>	<p>FRP GENERAL-PURPOSE FUME EXHAUSTERS</p> <p>73,000 CFM 17" WG</p> 	<p>FRP FUME EXHAUSTERS</p> <p>84,000 CFM 25" WG</p> 
--	--	--

PERFORMANCE FOR FRP PRESSURE BLOWERS

CFM		OV		Wheel diameter: 18" Wheel circumference: 4.71'								Inlet diameter: 8" I.D. Fan outlet area = .339 sq. ft.				Maximum BHP = $.360 \left[\frac{\text{RPM}}{1000} \right]^3$							
				10"SP		14"SP		18"SP		20"SP		22"SP		24"SP		26"SP		28"SP		30"SP		32"SP	
		RPM	BHP	RPM	BHP	RPM	BHP	RPM	BHP	RPM	BHP	RPM	BHP	RPM	BHP	RPM	BHP	RPM	BHP	RPM	BHP	RPM	BHP
600	1770	2254	1.7	2649	2.4	2996	3.2	3167	3.7	3326	4.1	3465	4.6	3616	5.1	3759	5.6	3891	6.1				
720	2124	2271	1.9	2664	2.8	3009	3.7	3160	4.1	3315	4.6	3455	5.1	3608	5.6	3741	6.1	3865	6.6	3998	7.2		
840	2478	2292	2.2	2685	3.2	3028	4.1	3187	4.7	3329	5.1	3471	5.7	3613	6.2	3738	6.7	3872	7.3	4000	7.9		
960	2832	2322	2.5	2710	3.6	3043	4.6	3198	5.2	3348	5.7	3492	6.3	3626	6.9	3770	7.5	3887	8.1				
1080	3186	2370	2.9	2737	4.0	3071	5.2	3223	5.7	3372	6.3	3517	7.0	3654	7.6	3781	8.2	3917	8.9				
1200	3540	2417	3.3	2767	4.5	3089	5.7	3236	6.3	3383	6.9	3527	7.6	3666	8.3	3797	9.0	3917	9.6				
1320	3894	2477	3.8	2818	5.0	3134	6.3	3280	7.0	3414	7.6	3559	8.4	3683	9.0	3817	9.8	3943	10.5				
1440	4248	2535	4.3	2868	5.6	3167	6.9	3313	7.7	3446	8.4	3577	9.1	3719	9.9	3841	10.6	3971	11.4				
1560	4602	2604	4.9	2924	6.3	3222	7.7	3357	8.4	3492	9.2	3625	10.0	3756	10.7	3867	11.5						
1680	4956	2670	5.5	2988	7.0	3276	8.5	3412	9.3	3537	10.0	3672	10.9	3793	11.7	3908	12.5						
1800	5310	2746	6.2	3057	7.8	3329	9.3	3465	10.2	3592	11.0	3718	11.8	3842	12.7	3962	13.6						
1920	5664	2820	6.9	3124	8.6	3398	10.3	3527	11.2	3646	12.0	3775	12.9	3891	13.8								
2040	6018	2898	7.8	3196	9.5	3464	11.3	3595	12.2	3718	13.2	3830	14.0	3949	15.0								
2160	6372	2985	8.7	3266	10.5	3530	12.4	3654	13.3	3770	14.2	3893	15.3										
2280	6726	3064	9.7	3341	11.6	3608	13.6	3727	14.6	3937	15.5	3955	16.5										
2400	7080	3152	10.7	3427	12.8	3677	14.8	3798	15.9	3911	16.9												

CFM		OV		Wheel diameter: 22" Wheel circumference: 5.76'								Inlet diameter: 10" I.D. Fan outlet area = .528 sq. ft.				Maximum BHP = $.728 \left[\frac{\text{RPM}}{1000} \right]^3$							
				14"SP		18"SP		22"SP		24"SP		26"SP		28"SP		30"SP		32"SP		34"SP		36"SP	
		RPM	BHP	RPM	BHP	RPM	BHP	RPM	BHP	RPM	BHP	RPM	BHP	RPM	BHP	RPM	BHP	RPM	BHP	RPM	BHP	RPM	BHP
950	1799	2211	3.5	2506	4.6	2779	5.9	2903	6.6	3026	7.3	3146	8.0	3261	8.8	3369	9.6	3467	10.3	3571	11.2		
1100	2083	2215	3.9	2505	5.0	2768	6.3	2901	7.1	3016	7.7	3127	8.4	3236	9.2	3351	10.0	3461	10.9	3564	11.7		
1250	2367	2225	4.3	2511	5.6	2767	6.9	2899	7.6	3006	8.3	3121	9.0	3235	9.8	3335	10.5	3453	11.5	3553	12.3		
1400	2652	2239	4.9	2523	6.2	2788	7.6	2904	8.3	3014	9.0	3132	9.8	3242	10.6	3339	11.3	3442	12.2	3552	13.1		
1550	2936	2256	5.4	2538	6.9	2798	8.4	2914	9.1	3026	9.9	3132	10.6	3245	11.5	3349	12.3	3440	13.0	3537	13.9		
1700	3220	2283	6.0	2557	7.6	2801	9.1	2917	9.9	3043	10.8	3152	11.7	3254	12.5	3363	13.4	3462	14.2	3549	15.0		
1850	3504	2325	6.7	2569	8.3	2819	10.0	2936	10.9	3050	11.8	3161	12.6	3267	13.5	3365	14.4	3470	15.3	3565	16.2		
2000	3788	2372	7.5	2601	9.1	2840	10.9	2957	11.9	3062	12.7	3175	13.7	3271	14.6	3373	15.5	3482	16.6	3568	17.4		
2150	4072	2430	8.3	2647	10.0	2872	11.9	2981	12.9	3077	13.8	3181	14.7	3291	15.8	3385	16.7	3485	17.7	3590	18.8		
2300	4356	2498	9.3	2707	11.1	2905	12.9	3006	13.9	3114	15.0	3211	16.0	3313	17.0	3400	18.0	3504	19.1				
2450	4640	2553	10.1	2765	12.2	2953	14.1	3049	15.1	3143	16.1	3242	17.2	3338	18.3	3429	19.4	3526	20.5				
2600	4924	2617	11.2	2828	13.3	3016	15.5	3100	16.4	3189	17.5	3274	18.5	3364	19.6	3459	20.8	3549	21.9				
2750	5208	2674	12.3	2889	14.5	3077	16.8	3165	18.0	3242	18.9	3324	20.0	3409	21.1	3499	22.3	3574	23.4				
2900	5492	2735	13.5	2943	15.7	3136	18.2	3221	19.4	3302	20.5	3388	21.7	3470	22.9	3539	23.9						
3050	5777	2800	14.9	3007	17.2	3194	19.6	3282	20.9	3361	22.1	3451	23.5	3522	24.6	3596	25.8						
3200	6061	2869	16.4	3065	18.7	3251	21.1	3343	22.5	3426	23.8	3512	25.3	3588	26.6								

CFM		OV		Wheel diameter: 28" Wheel circumference: 7.33'								Inlet diameter: 12" I.D. Fan outlet area = .839 sq. ft.				Maximum BHP = $2.70 \left[\frac{\text{RPM}}{1000} \right]^3$							
				12"SP		14"SP		16"SP		18"SP		20"SP		22"SP		24"SP		26"SP		28"SP		30"SP	
		RPM	BHP	RPM	BHP	RPM	BHP	RPM	BHP	RPM	BHP	RPM	BHP	RPM	BHP	RPM	BHP	RPM	BHP	RPM	BHP	RPM	BHP
1250	1490	1557	4.0	1686	4.7	1799	5.5	1912	6.4	2021	7.2	2122	8.1	2221	9.1	2317	10.0	2409	11.0	2494	12.0		
1500	1788	1552	4.5	1683	5.4	1799	6.3	1905	7.2	2008	8.1	2115	9.1	2214	10.1	2302	11.1	2398	12.2	2478	13.2		
1750	2086	1558	5.2	1681	6.1	1794	7.0	1906	8.1	2005	9.0	2108	10.1	2207	11.2	2289	12.2	2378	13.3	2473	14.5		
2000	2384	1573	5.9	1693	6.9	1805	8.0	1911	9.0	2008	10.0	2103	11.1	2200	12.3	2293	13.5	2377	14.6	2467	15.9		
2250	2682	1590	6.7	1703	7.8	1817	8.9	1920	10.0	2015	11.2	2109	12.3	2201	13.5	2287	14.7	2381	16.1	2453	17.2		
2500	2980	1618	7.6	1727	8.8	1831	9.9	1931	11.1	2025	12.3	2119	13.6	2211	14.9	2299	16.2	2383	17.5	2460	18.8		
2750	3278	1650	8.6	1757	9.9	1853	11.0	1952	12.3	2045	13.6	2130	14.9	2223	16.3	2303	17.6	2389	19.1	2469	20.5		
3000	3576	1685	9.7	1786	11.0	1881	12.3	1979	13.7	2066	15.0	2152	16.4	2237	17.8	2319	19.3	2398	20.7	2482	22.3		
3250	3874	1724	10.8	1825	12.3	1914	13.6	2006	15.1	2094	16.6	2174	17.9	2261	19.5	2337	21.0	2419	22.6	2496	24.1		
3500	4172	1765	12.1	1861	13.6	1952	15.1	2039	16.6	2122	18.1	2204	19.7	2285	21.3	2364	22.9	2440	24.5				
3750	4470	1809	13.5	1901	15.1	1988	16.6	2077	18.3	2155	19.9	2240	21.6	2316	23.2	2391	24.9	2462	26.5				
4000	4768	1855	15.0	1945	16.7	2033	18.4	2113	20.1	2194	21.8	2274	23.5	2347	25.2	2425	27.1	2492	28.7				
4250	5066	1904	16.7	1991	18.4	2077	20.2	2159	22.1	2237	23.9	2308	25.6	2384	27.4	2451	29.1						
4500	5364	1960	18.6	2041	20.3	2119	22.1	2199	24.0	2274	25.9	2354	27.9	2420	29.7	2491	31.6						
4750	5662	2010	20.5	2093	22.4	2170	24.3	2248	26.3	2320	28.2	2392	30.2	2462	32.2								
5000	5959	2066	22.7	2144	24.6	2219	26.6	2295	28.7	2366	30.7	2441	32.9										

Performance shown is installation Type D: Ducted inlet, Ducted outlet. Power rating (BHP) does not include drive losses. Performance ratings do not include the effects of appurtenances in the airstream.

SPECIFICATIONS

Size	Shaft diameter [inches]		Bearings		Weight [lbs.]					Wheel WR ² [lb.-ft. ²]
	Arr. 1,8	Arr. 10	Arr. 1,8	Arr. 10	Bare fan			Wheel and shaft assembly		
					Arr. 1	Arr. 8	Arr. 10	Arr. 1,8	Arr. 10	
RFE-160	NA	1 ⁷ / ₁₆	NA	A	NA	NA	125	NA	13	.09
RFE-200	NA	1 ⁷ / ₁₆	NA	A	NA	NA	150	NA	15	.30
RFE-315	NA	1 ¹¹ / ₁₆	NA	A	NA	NA	213	NA	26	1.4
RFE-400	NA	1 ¹⁵ / ₁₆	NA	A	NA	NA	342	NA	44	4.5
RFE-500	NA	1 ¹⁵ / ₁₆	NA	A	NA	NA	375	NA	54	12.4
FPB-18	1 ⁷ / ₁₆	1 ⁷ / ₁₆	A	A	290	540	182	28	32	4.3
FPB-22	1 ⁷ / ₁₆	1 ¹¹ / ₁₆	D	A	370	680	320	50	60	9.2
FPB-28	1 ¹¹ / ₁₆	1 ¹¹ / ₁₆	D	A	610	740	410	65	67	27.5

A—Link Belt P3-U200 ball bearings. D—Linkbelt P-U300 ball bearings. NA—not available.
nyb reserves the right to substitute bearings of equal quality.

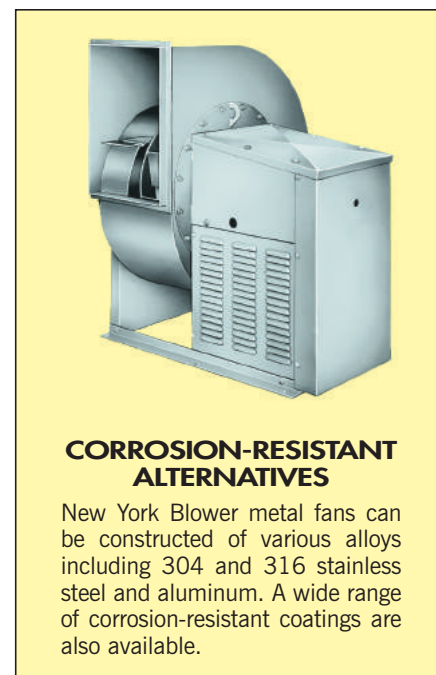

CORROSION-RESISTANT ALTERNATIVES

New York Blower metal fans can be constructed of various alloys including 304 and 316 stainless steel and aluminum. A wide range of corrosion-resistant coatings are also available.

CORROSION-RESISTANCE GUIDE

FRP fans are used to exhaust highly corrosive gases or fumes from various processes. Following is a list of corrosive substances, including acids, alkalies, salts, and solvents, commonly encountered in these applications. Refer to nyb Engineering Letter 18 for a more comprehensive listing.

Corrosive agent	Std. FRP const.
Acetic Acid	R
Acrylic Acid	R
Ammonia	R
Ammonium Carbonate	R
Ammonium Hydroxide	V
Ammonium Sulfite	R
Arsenious Acid	R
Barium Carbonate	R
Benzoic Acid	R
Boric Acid	R
Bromine, Dry Gas	R
Bromine, Moist Gas	R
Butyl Acetate	R
Butylene Glycol	R
Butyric Acid	R
Calcium Sulfate	R
Carbon Dioxide	R
Carbon Disulfide Vapor	R
Carbon Tetrachloride	R
Chlorine Gas, Dry	V
Chlorine Gas, Wet	V
Chlorofluorocarbon	R
Chrome-Plating Bath	R
Chromic Acid	R
Citric Acid	R
Copper Cyanide	R
Copper Nitrate	R
Copper Sulfate	R
Cyclohexane	R
Diethyl Glycol	R
Dimethyl Sulfoxide	R
Dimethylamine	R
Dipropylene Glycol	R
Ether	R
Ethyl Alcohol	R
Ethyl Chloride	R
Ethylene Glycol	R
Fatty Acids	R
Ferric Nitrate	R
Ferrous Chloride	R

Corrosive agent	Std. FRP const.
Fluoboric Acid	V
Fluosilicic Acid	V
Formaldehyde	R
Formic Acid	R
Glycerine	R
Glycolic Acid	R
Heptane	R
Hexane	R
Hydrochloric Acid Fumes	D
Hydrocyanic Acid	R
Hydrofluoric Acid	D*
Hydrogen Bromide	R
Hydrogen Chloride	R
Hydrogen Fluoride	V*
Hydrogen Peroxide	R
Hydrogen Sulfide	R
Hydroxyacetic Acid	R
Hypochlorous Acid	R
Iodine	R
Kerosene	R
Lactic Acid	R
Lithium Chloride	R
Magnesium Carbonate	R
Magnesium Chloride	R
Malathion	R
Maleic Acid	R
Mercuric Chloride	R
Mercury	R
Methacrylic Acid	R
Methyl Alcohol	R
Methyl Bromide	R
Methyl Chloride	R
Naphtha	R
Naphthalene	R
Nickel Nitrate	R
Nitric Acid	R
Nitrous Acid	R
Oleic Acid	R
Oxalic Acid	R
Ozone	R

Corrosive agent	Std. FRP const.
Palmitic Acid	R
Perchloroethylene	R
Perchloric Acid	R
Petroleum Ether	R
Phosphoric Acid	R
Phosphorous Acid	R
Phthalic Acid	R
Phthalic Anhydride	R
Polyvinyl Alcohol	R
Polyvinylidene Chloride	R
Potassium Bicarbonate	V
Potassium Ferrocyanide	R
Potassium Permanganate	R
Propionic Acid	R
Propylene Glycol	R
Silver Nitrate	R
Sodium Acetate	R
Sodium Benzoate	R
Sodium Chloride	R
Sodium Dichromate	R
Sodium Hydroxide	V
Sodium Nitrate	R
Stannic Chloride	R
Stearic Acid	R
Styrene	R
Sulfamic Acid	R
Sulfur Dichloride	R
Sulfur Dioxide	R
Sulfuric Acid	R
Sulfurous Acid	R
Tannic Acid	R
Tartaric Acid	R
Tetrachloroethane	R
Toluene	R
Trichloroacetic Acid	R
Turpentine	R
Vinegar	R
Water, Sea	R
Water, Steam Condensate	R
Xylene	R

R—Recommended. V—Synthetic surface veil required. D—Double layer synthetic surface veil required. N—Not recommended. T—Test data not available. *—120°F. maximum.

FRP RADIAL FUME EXHAUSTERS

ARRANGEMENT

10

DIMENSIONS

[inches/millimeters]

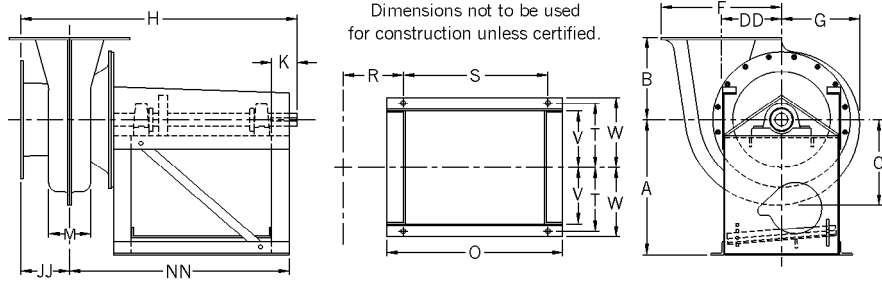

Size	A		B		C		DD		F		G		H		JJ		K		M		NN		O		R	
	in.	mm	in.	mm	in.	mm	in.	mm	in.	mm	in.	mm	in.	mm	in.	mm	in.	mm	in.	mm	in.	mm	in.	mm	in.	mm
160	15½	394	8¾	206	8½	206	5½	140	11	280	7¼	185	30⅞	784	5¼	134	2½	64	4¼	108	24¾	629	19⅞	505	6¾	171
200	15½	394	9½	241	9⅞	251	6¾	172	13⅝	346	8⅞	225	32¼	819	5¼	146	2½	64	5¼	133	24⅞	632	19⅞	505	6¾	171
315	21¼	540	13¾	337	13⅝	340	9½	242	19⅞	486	11⅞	300	39⅝	1006	6¾	171	3½	89	7¼	184	28½	724	21⅞	556	8⅞	226
400	25½	648	17	432	16⅞	422	11⅞	302	23⅝	600	14¾	375	47	1193	8⅞	219	4	102	9¼	234	33⅝	854	25⅞	657	10½	267
500	28	711	20¾	528	20	508	13¾	350	27⅞	702	17¾	450	49¾	1264	9½	241	4¼	108	11⅞	282	34⅞	866	25⅞	657	11¼	285

Size	S		T		V		W		a		b		c		d		Base holes	Square key	Maximum motor frame size		Maximum motor case length [C-NW]	Minimum motor HP**		
	in.	mm	in.	mm	in.	mm	in.	mm	in.	mm	in.	mm	in.	mm	in.	mm	in.	mm	Open	TEFC				
160	16⅝	416	7⅞	187	6½	165	8	203	7⅞	194	13⅝	340	8⅞	213	6⅞	175	⅞	9.5	215T	184T	14½	⅓		
200	16⅝	416	7⅞	187	6½	165	8	203	9⅞	238	16¼	413	10⅞	264	8¼	210	⅞	9.5	215T	184T	14½	⅓		
315	17⅞	441	9⅞	238	8¼	210	10¼	260	13	330	22½	572	14⅞	359	11	279	⅞	9.5	215T	215T	16⅞	⅓		
400	20⅞	518	10⅞	276	9¾	248	11¾	298	15¾	400	29¼	743	17⅞	441	13⅝	346	⅞	12.7	256T	254T	18⅞	½		
500	19⅞	505	12¼	311	11	279	13	330	18⅞	473	35¼	895	21⅞	537	16¼	413	¾	19	½	12.7	256T	254T	18⅞	½

** This represents the minimum HP required for fan start-up with 3-phase motor.

Tolerance: ± ⅛" or ± 3 mm.

FLANGED INLET AND OUTLET DIMENSIONS

for FRP Radial Fume Exhausters and FRP Pressure Blowers [inches/millimeters]

Size	Inlet and outlet flanges*														
	I. D.		B. C. [bolt circle]				O. D.		Number of holes	Diameter of holes		Flange thickness			
			PS 15-69		ANSI Class 150					PS 15-69			ANSI Class 150		
	in.	mm	in.	mm	in.	mm	in.	mm	in.	mm	in.	mm	in.	mm	
RFE-160	6¼	160	9	229	9½	241	11	279	8	⅞	11	⅞	22	⅝	8
RFE-200	7⅞	200	11	279	11¾	298	13½	343	8	⅞	11	⅞	22	⅝	8
RFE-315	12½	315	15	381	17	432	19	483	12	⅞	11	1	25	⅞	11
RFE-400	15¾	400	19	483	21¼	540	23⅝	600	16	⅞	11	1⅞	29	½	13
RFE-500	19¾	500	23	584	25	635	27½	699	20	⅞	11	1¼	32	½	13
FPB-18	8	203	11	279	11¾	298	13½	343	8	⅞	11	⅞	22	½	13
FPB-22	10	254	13	330	14¼	362	16	406	12	⅞	11	1	25	½	13
FPB-28	12	305	15	381	17	432	19	483	12	⅞	11	1	25	½	13

* Flanges are furnished standard without holes. Choice of either PS 15-69 or ANSI Class 150 drilling patterns available. Holes straddle centerline except on inlet flange of the following fans in angular discharge positions: RFE-315, RFE-500, FPB-22, and FPB-28. Tolerance: ± ⅛" or ± 3 mm.

FAN DISCHARGES – VIEWED FROM DRIVE SIDE

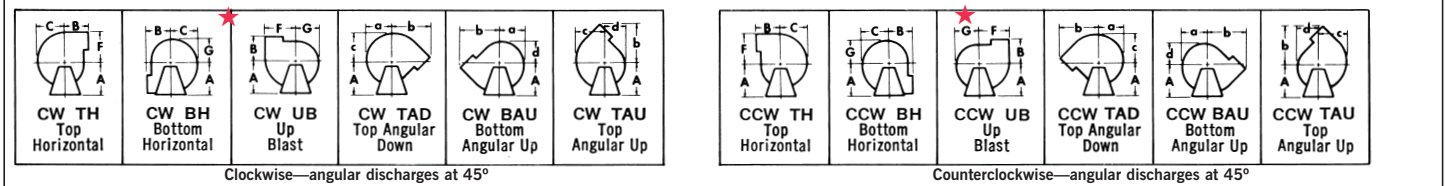

★ Bottom Horizontal fans, Size FPB-28 only, are equipped with a 3-inch channel sub-base...add 3" to the fan centerline height.

The New York Blower Company has a policy of continuous product development and reserves the right to change designs and specifications without notice.

FRP PRESSURE BLOWERS

ARRANGEMENT **1 AND 8** DIMENSIONS [inches/millimeters]

Dimensions not to be used for construction unless certified.

Dotted structure represents Arrangement 8 construction.

Size	A		B		C		DD		F		G		H		JJ		K		M		NN	
	in.	mm	in.	mm	in.	mm	in.	mm	in.	mm	in.	mm	in.	mm	in.	mm	in.	mm	in.	mm	in.	mm
18	18½	470	17	432	14	356	10½	267	17¼	438	13¼	337	27¼	692	6⅝	168	3	76	7	178	17⅝	448
22	24½	622	22	559	18⅝	460	14⅞	378	22⅞	581	17⅝	435	28⅝	721	6¾	171	4	102	7⅞	181	17¾	451
28	27	686	28	711	22⅝	575	18⅞	479	28⅝	721	21⅝	543	31¾	806	8⅝	206	5	127	9	229	18⅝	473

Size	R		S		T		W		a		b		c		d		Base holes		Square key	
	in.	mm	in.	mm	in.	mm	in.	mm	in.	mm	in.	mm	in.	mm	in.	mm	in.	mm	in.	mm
18	4⅝	117	12	305	10¼	260	11⅝	283	13⅝	346	24¼	616	14⅜	365	12⅞	327	⅞	14	⅜	9.5
22	4¾	121	12	305	10⅞	276	11¾	298	17⅞	448	31¾	806	18⅞	473	16⅝	422	⅞	14	⅜	9.5
28	5⅝	143	12	305	10⅞	276	11¾	298	22	559	39⅞	1013	23¼	591	20¾	527	⅞	14	⅜	9.5

Tolerance: ± ⅛" or ± 3 mm.

ARRANGEMENT 8 FRP PRESSURE BLOWER DIMENSIONS [in./mm]

Motor frame	Size 18						Size 22						Size 28							
	HH*		SS		XX		HH*		SS		XX		HH*		SS		XX			
	in.	mm	in.	mm	in.	mm	in.	mm	in.	mm	in.	mm	in.	mm	in.	mm	in.	mm		
143T-145T	41⅝	1045	14	356	31⅞	810	42¼	1073	15¼	387	33¼	845	—	—	—	—	—	—	—	—
182T-184T	45½	1156	15½	394	33⅜	848	46⅝	1184	16¾	425	34¾	883	50	1270	17¾	451	36⅝	930	—	—
213T-215T	47⅞	1216	18¾	476	36⅝	930	49	1245	19¾	502	37¾	959	52⅝	1330	20¾	527	39⅝	1006	—	—
254T-256T	—	—	—	—	—	—	54⅝	1387	25	635	43	1092	58	1473	26	660	44⅞	1140	—	—
284TS-286TS	—	—	—	—	—	—	—	—	—	—	—	—	59½	1511	26¾	679	45⅝	1159	—	—
324TS-326TS	—	—	—	—	—	—	—	—	—	—	—	—	62	1575	29¼	743	48⅝	1222	—	—

* HH dimension is for reference only and is based on the maximum motor lengths for standard TEFC, 1800 RPM motors.

Tolerance: ± ⅛" or ± 3 mm.

ARRANGEMENT **10** DIMENSIONS [inches/millimeters]

Dimensions not to be used for construction unless certified.

Size	A		B		C		DD		F		G		H		JJ		K		M		NN		O		R	
	in.	mm	in.	mm	in.	mm	in.	mm	in.	mm	in.	mm	in.	mm	in.	mm	in.	mm	in.	mm	in.	mm	in.	mm	in.	mm
18	17½	445	17	432	14	356	10½	267	17¼	438	13¼	337	33⅝	841	6⅝	168	3	76	7	178	25½	648	21⅞	556	5⅝	137
22	25⅝	645	22	559	18⅝	460	14⅞	378	22⅞	581	17⅝	435	37⅞	962	6¾	171	4	102	7⅞	181	29⅝	752	25⅞	657	6½	165
28	27⅞	708	28	711	22⅝	575	18⅞	479	28⅝	721	21⅝	543	40	1016	8⅝	206	4	102	9	229	30½	775	25⅞	657	7⅞	194

Size	S		T		V		W		a		b		c		d		Base holes		Square key		Maximum motor frame size		Maximum motor case length [C-NW]	Minimum motor HP**
	in.	mm	in.	mm	in.	mm	in.	mm	in.	mm	in.	mm	in.	mm	in.	mm	in.	mm	in.	mm	Open	TEFC		
18	18⅝	467	8⅞	225	8	203	9½	241	13⅝	346	24¼	616	14⅜	365	12⅞	327	⅞	14	⅜	9.5	215T	215T	16⅝	½
22	20⅝	518	10⅞	276	9¾	248	11¾	298	17⅞	448	31¾	806	18⅞	473	16⅝	422	⅞	14	⅜	9.5	256T	254T	18⅞	½
28	19⅞	505	12¼	311	11	279	13	330	22	559	39⅞	1013	23¼	591	20¾	527	¾	19	⅜	9.5	256T	254T	18⅞	½

** This represents the minimum HP required for fan start-up with 3-phase motor.

Tolerance: ± ⅛" or ± 3 mm.

IN **CORROSION-RESISTANT**

FRP FANS...

STANDARDS MAKE A DIFFERENCE!

In FRP Fans, construction quality and accurate air ratings are vital. That's where standards make a big difference.

The American Society for Testing and Materials [ASTM] developed a standard specification for FRP fans and blowers. ASTM D 4167, Standard Specification for FIBER-REINFORCED PLASTIC FANS AND BLOWERS, defines minimum specifications for construction of major fan elements. It is a concise, understandable, readily available standard.

The Air Movement and Control Association's [AMCA] Certified Ratings Program provides assurance of accurate ratings. AMCA Standard 210 describes how fans are to be tested for air performance. The AMCA Certified Ratings Program requires the fan manufacturer to guarantee aerodynamic performance within close tolerances of the manufacturer's published ratings.

The Society of the Plastic Industry's [SPI] Users Guide to RP Industrial Equipment, #2-Fans, Guide for Purchasing or Specifying Reinforced Plastic Fans and Blowers, recommends specification of both the ASTM and AMCA standards.

The New York Blower Company's complete line of FRP Fans—Fume Exhausters, Radial Fume Exhausters, Pressure Blowers, General-Purpose Fume Exhausters, and Tubeaxial Fans—meet these standards.



FRP PRESSURE BLOWERS

5,000 CFM
36" WG



FRP RADIAL FUME EXHAUSTERS

7,500 CFM
14" WG



FRP FUME EXHAUSTERS

84,000 CFM
25" WG



FRP GENERAL-PURPOSE FUME EXHAUSTERS

73,000 CFM
17" WG



FRP TUBEAXIAL FANS

90,000 CFM
4" WG



THE BEST FRP FANS STILL KEEP COMING FROM NEW YORK BLOWER!