

# SERIES 20 MATERIAL SPECIFICATIONS

## MAXIMUM SAFE SPEEDS, SHAFTS, AND BEARINGS FOR SERIES 20 LS, DH, AH, AND AM WHEELS AT 70°

Size	Wheel Max Safe Speed			Arr. 1, 8, 9, 9E, 9F		Arr. 10		LS Wheel			DH Wheel					AH Wheel		AM Wheel	
	Arr. 1, 8, 9, 9F	Arr. 9E	Arr. 10	Shaft Dia.	Bearing	Shaft Dia.	Bearing	Blades	Weight	WR <sup>2</sup>	Backplate	Frontplate	Blades	Weight	WR <sup>2</sup>	Weight	WR <sup>2</sup>	Weight	WR <sup>2</sup>
144	4605	3980	4605	1 <sup>3</sup> / <sub>16</sub>	B	1 <sup>7</sup> / <sub>16</sub>	A	10	15	1.5	-	-	-	-	-	25	3.8	20	2.0
174	3930	3930	3745	1 <sup>7</sup> / <sub>16</sub>	B	1 <sup>7</sup> / <sub>16</sub>	A	10	19	2.8	-	-	-	-	-	33	7.8	29	4.4
194	3425	3425	3115	1 <sup>11</sup> / <sub>16</sub>	C	1 <sup>11</sup> / <sub>16</sub>	A	7	34	5	7	10	49	11	55	15	46	12	
224	2900	2900	2635	1 <sup>11</sup> / <sub>16</sub>	C	1 <sup>15</sup> / <sub>16</sub>	A	7	45	13	7	10	63	21	72	28	60	24	
264	2510	2510	2280	2 <sup>3</sup> / <sub>16</sub>	C	1 <sup>15</sup> / <sub>16</sub>	A	7	77	20	7	10	78	36	91	49	74	41	
294	2195	2195	1995	2 <sup>3</sup> / <sub>16</sub>	C	1 <sup>15</sup> / <sub>16</sub>	B	7	85	42	7	10	102	69	123	87	100	71	
334	2035	2035	1790	2 <sup>3</sup> / <sub>16</sub>	D	2 <sup>3</sup> / <sub>16</sub>	B	7	103	63	1/4	7	10	157	119	189	167	162	134
364	1840	-	1620	2 <sup>7</sup> / <sub>16</sub>	D	2 <sup>3</sup> / <sub>16</sub>	B	7	115	86	1/4	7	10	184	178	229	251	195	200
404	1640	-	-	2 <sup>7</sup> / <sub>16</sub>	D	-	-	7	126	114	1/4	7	261	327	-	-	-	-	
454	1460	-	-	2 <sup>11</sup> / <sub>16</sub>	D	-	-	1/4	256	294	1/4	7	349	515	-	-	-	-	
504	1305	-	-	2 <sup>15</sup> / <sub>16</sub>	D	-	-	1/4	287	423	1/4	7	420	805	-	-	-	-	
574	1145	-	-	2 <sup>15</sup> / <sub>16</sub>	D	-	-	1/4	338	630	1/4	7	651	1623	-	-	-	-	
644	1025	-	-	3 <sup>7</sup> / <sub>16</sub>	D	-	-	1/4	552	1290	3/8	1/4	858	2738	-	-	-	-	
714	925	-	-	3 <sup>15</sup> / <sub>16</sub>	D	-	-	1/4	609	1744	3/8	1/4	1116	4116	-	-	-	-	
784	840	-	-	3 <sup>15</sup> / <sub>16</sub>	D	-	-	1/4	860	2970	3/8	1/4	1306	5970	-	-	-	-	
854	770	-	-	4 <sup>7</sup> / <sub>16</sub>	E	-	-	1/4	927	3800	3/8	1/4	1518	7810	-	-	-	-	

**NOTE:** All weights in lbs.

Bearing Types:

- A Standard Duty Ball, Concentric Lock
- B Medium Duty Ball, Concentric Lock
- C Heavy Duty Ball, Concentric Lock
- D Spherical Roller, Set Screw Mount (2 Bolt Base)
- E Spherical Roller, Set Screw Mount (4 Bolt Base)

## MATERIAL SPECIFICATIONS FOR STANDARD STEEL SERIES 20 FANS

Size	Housing				Bearing Pedestal Arr. 1, 9, 9E, 9F Motor Pedestal Arr. 9F (404-574)			Bearing Pedestal Arr. 10				Bare Fan Weights [lbs.]						
	Sides	Scroll	Plates		Inlet Collar	Top	Sides	Base Bars	Bearing Pedestal			Motor Platform	Base Angles	Arr. 1, 9	Arr. 9E	Arr. 9F	Arr. 10	Arr. 4
			Inlet	Drive					Top	Sides	Ends							
144	12	12	10	12	10	10	12	7	1 <sup>1</sup> / <sub>2</sub> x 1 <sup>1</sup> / <sub>2</sub> x 3 <sup>3</sup> / <sub>16</sub>	130	135	-	135	107				
174	12	10	12	10	10	10	12	7	1 <sup>1</sup> / <sub>2</sub> x 1 <sup>1</sup> / <sub>2</sub> x 3 <sup>3</sup> / <sub>16</sub>	175	181	-	175	145				
194	10	10	7	7	7	7	12	7	2 x 2 x 3 <sup>3</sup> / <sub>16</sub>	305	309	-	300	237				
224	10	10	7	7	7	7	10	7	2 x 2 x 3 <sup>3</sup> / <sub>16</sub>	365	376	-	420	317				
264	10	10	7	7	7	7	10	1/4	2 x 2 x 3 <sup>3</sup> / <sub>16</sub>	460	473	-	530	410				
294	10	10	7	1/4	7	7	10	7	1/4	3 x 3 x 3 <sup>3</sup> / <sub>16</sub>	715	725	-	675	515			
334	10	10	7	1/4	7	7	10	7	1/4	3 x 3 x 3 <sup>3</sup> / <sub>16</sub>	920	933	-	880	688			
364	10	7	7	1/4	7	7	10	7	1/4	3 x 3 x 3 <sup>3</sup> / <sub>16</sub>	1170	-	-	1010	932			
404	7	7	-	7	1/4	3/8	-	-	-	-	-	-	1340	-	1630	-	-	
454	7	7	-	7	1/4	3/8	-	-	-	-	-	-	1830	-	2095	-	-	
504	7	7	-	7	1/4	3/8	-	-	-	-	-	-	2205	-	2515	-	-	
574	7	7	-	7	3/8	1/4	3/8	-	-	-	-	-	2955	-	3340	-	-	
644	1/4	7	1/4	-	1/4	3/8	-	-	-	-	-	-	4665	-	-	-	-	
714	1/4	7	1/4	-	1/4	3/8	-	-	-	-	-	-	5255	-	-	-	-	
784	1/4	7	1/4	-	1/4	3/8	-	-	-	-	-	-	6440	-	-	-	-	
854	1/4	7	1/4	-	1/4	3/8	-	-	-	-	-	-	8145	-	-	-	-	

# HOUSING DIMENSIONS – SERIES 20 AND 30 ALL ARRANGEMENTS

Size	B	C	D	E	F	G	J		L [O.D.]		L [I.D.]	M	a	b†	c	d
									Ser. 20							
							Slip	Flanged*	LS, DH	AH, AM	Ser. 30					
144	10½	11⅞	8⅜	9⅜	12	10¼	1⅝		9	8	8¾	7⅞	10¾	16	11½	9¾
174	12⅝	13⅜	10¼	11⅞	14½	12¼	1⅝		11	9¾	10¾	9½	13⅞	19¼	13¾	11½
194	14	15⅝	10⅞	11⅝	17⅝	13⅝	3⅞	3⅜	11		10⅝	9¾	15	22⅝	17	13
224	16½	18⅜	13	14¼	21⅜	16⅞	3⅞	3⅜	13		12⅝	10¾	17⅝	26⅝	20	15¼
264	18½	21⅝	14⅝	16⅜	24⅞	18⅝	4⅞	4⅜	15		14⅝	12⅜	20¼	30⅜	23	17½
294	21	24⅞	16⅞	18⅝	27⅝	21⅞	4⅞	4⅜	17		16⅝	14	23	34⅜	26⅞	19⅞
334	23	27⅞	18¾	20⅜	30⅞	23⅞	4⅞	4⅜	19		18⅝	15⅝	25¾	38⅞	29¼	22⅜
364	25½	30¼	20⅝	22½	34⅞	26⅜	5¼	5½	21		20⅝	17¼	28½	42⅞	32¼	24⅝
404	28	33⅝	22⅜	24⅜	37⅞	29	5¼	5½	23	–	22⅝	19	31⅞	46¼	35⅞	27
454	31½	37⅞	25⅝	27⅝	42⅞	32⅝	5¼	5½	26	–	25⅝	21⅜	35⅞	52¼	40	30⅝
504	34½	41⅞	28⅝	31¼	47⅞	36⅞	6	6¼	29	–	28⅝	23⅞	39⅞	57¾	44⅝	34⅞
574	39	47⅞	32⅝	35⅞	53⅞	41⅞	7	7¼	33	–	32⅝	27⅞	44¾	65⅞	50¾	38¾
644	43	53⅝	36½	39¾	60⅝	46½	7¼	7½	37	–	36½	30½	50¼	72⅞	57	43½
714	47½	58⅝	40⅝	44¼	66⅞	51½	7¼	7½	41	–	40½	33⅝	55½	80⅞	62⅞	48
784	52	64¾	44¼	48⅜	72⅝	56⅞	7¼	7½	45	–	44½	36⅞	60⅞	88½	69	52¾
854	57	70½	48⅜	52⅞	79⅞	61½	7¼	7½	49	–	48½	40⅞	66⅜	96⅞	75	57⅞

\* Flanged inlet standard on Series 30. Dimensions are for drawings shown on pages 23 through 27.

† Maximum with outlet flange.

## UNITARY BASE

Structural steel channel base provides factory-designed package of fan, motor, drive, and belt guard. Also available with rubber-in-shear or spring isolation. Built-in motor rails allow adjustment of belt tension.

Unitary base with isolation is also available for Arrangement 8, 9, and 9F fans.

**NOTE:** Down Blast discharge requires special construction. Also, some larger Series 20 GI Fans on unitary bases cannot be shipped as an assembled package.

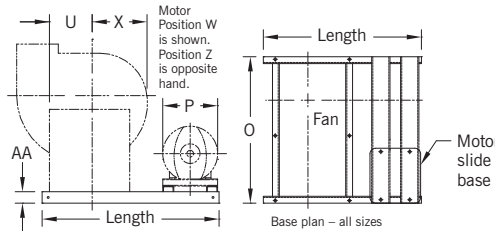

Approximate base length =  $U + X + P + 16$   
 $U$  = from fan base dimension drawing on pages 18-19.

$X$  = dimension from fan centerline to edge of scroll nearest motor. Dimension varies with discharge and motor position. Refer to dimensional drawings on pages 18-19.

$P$  = diameter of motor from table shown.

16 = constant - allows for motor clearance.

**NOTE:** These dimensions are only approximate. Exact dimensions furnished after order is placed.

## DIMENSIONS [INCHES]

Size	AA		O	Motor frame	Typical P dim. TEFC motor
	Unitary base with isolation	Standard Unitary Base			
144	3*	3*	20½	143T	7¾
174	3*	3*	25	145T	7¾
194	3*	3*	28¾	182T	9½
224	3*	3*	30¾	184T	9½
264	4†	4†	35¾	213T	12
294	4†	4†	39¾	215T	12
334	4†	4†	42¾	254T	14½
364	6	6	47	256T	14½
404	6	6	52¾	284T	15¼
454	6	6	57¼	286T	15¼
504	6	6	62¼	324T	17⅜
574	8	6	68½	326T	17⅜
644	8	6	74½	364T	19½
714	8	6	80¾	365T	19½
784	8	6	88	404T	21⅝
854	8	6	95¼	405T	21⅝
				444T	24½
				445T	24½
				447T	24½
				449T	24½

\*4" channel used for motors larger than 215T.  
 †6" channel used for motors larger than 286T.

## AMCA STANDARD MOTOR POSITIONS

Drawing below shows AMCA motor position designations for Arrangement 1 fans. These designations are required when ordering:

1. V-belt drives.
2. Vibration and unitary bases.
3. Belt guards.

Motor positions are independent of fan rotation and discharge positions and are determined by viewing fan from drive end and selecting W, X, Y, or Z.

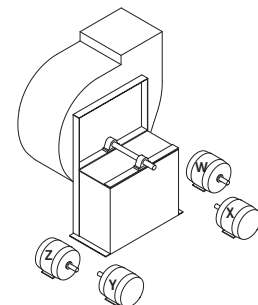

## DIMENSIONS

L, M, and D are outside dimensions.

J is from housing side over inlet collar.

Tolerance:  $\pm 1/8''$

Dimensions not to be used for construction unless certified.

Refer to page 7 for maximum motor size limits.

# SERIES 20, ARRANGEMENT 10

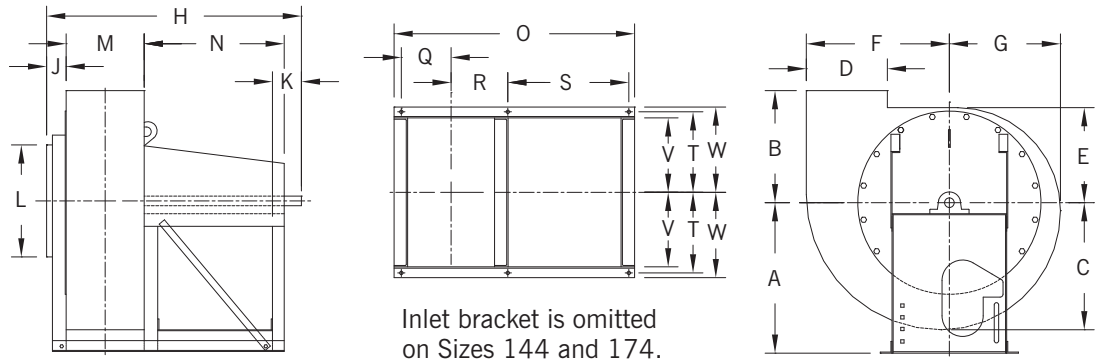

Inlet bracket is omitted on Sizes 144 and 174.

## DIMENSIONS [INCHES]

Size	A	H	K	N	O	Q	R	S	T	V	W	Base Holes
144	15 1/2	30	2 1/2	20	19 7/8	-	5 7/8	16 3/8	7 3/8	6 1/2	8	9/16
174	17 1/2	34 1/8	3	22	21 7/8	-	6 5/8	18 3/8	8 7/8	8	9 1/2	9/16
194	21 1/4	36 3/8	3 1/2	22	33 7/8	6	7 1/4	17 3/8	9 3/8	8 1/4	10 1/4	9/16
224	25 1/2	41 3/8	4	26	38 7/8	6 1/2	8 1/4	20 3/8	10 7/8	9 3/4	11 3/4	9/16
264	28	44 1/2	4 1/2	26	41 1/2	7 7/8	9 3/8	19 7/8	12 1/4	11	13	3/4
294	32 1/2	48	5 1/2	26 7/8	44	8 5/8	10 1/8	20 3/4	13 5/8	11 3/4	14 3/4	3/4
334	39 1/2	53 1/8	6	29 7/8	48 5/8	9 3/8	11	23 3/4	16	14	17	3/4
364	39 1/2	56	6	30	50 3/8	10 1/4	11 7/8	23 3/4	16	14	17	3/4

## FAN DISCHARGES – VIEWED FROM DRIVE SIDE

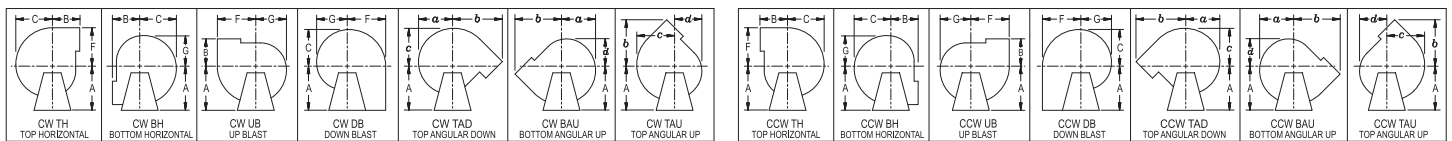

Clockwise—angular discharges at 45°

Counterclockwise—angular discharges at 45°

## FLANGED INLET DETAILS

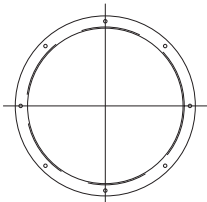

Furnished with holes starting on vertical centerline.

Inlet bar sizes:  
Sizes 144-174

10 ga. x 1 1/4

Size 194

7 ga. x 1 1/2

Sizes 224-364

1/4 x 1 1/2

Sizes 404-854

1/4 x 2

## DIMENSIONS [INCHES]

Size	I.D.*	B.C.	O.D.	Holes	
				No.	Dia.
144	8 3/4	10 1/4	11 1/2	6	7/16
174	10 3/4	12 1/4	13 1/2	6	7/16
194	10 5/8	12 1/2	14	8	7/16
224	12 5/8	14 1/2	16	8	7/16
264	14 5/8	16 1/2	18	8	7/16
294	16 5/8	18 1/2	20	8	7/16
334	18 5/8	20 1/2	22	16	7/16
364	20 5/8	22 1/2	24	16	7/16
404	22 5/8	25	27	16	9/16
454	25 5/8	28	30	16	9/16
504	28 5/8	31	33	16	9/16
574	32 5/8	35	37	16	9/16
644	36 1/2	39	41	24	9/16
714	40 1/2	43	45	24	9/16
784	44 1/2	47	49	24	9/16
854	48 1/2	51	53	24	9/16

\*Dimension shown is I.D. of inlet collar.

## FLANGED OUTLET DETAILS

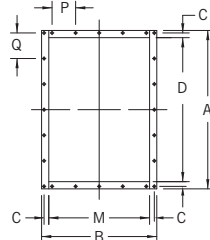

1. Mounted flush with edge of housing outlet.

2. Holes furnished on 4" centers on centerline.

Outlet flange angles:

Sizes 144-174

1 1/4 x 1 1/4 x 3/16

Sizes 194-364

1 1/2 x 1 1/2 x 3/16

Sizes 404-854

2 x 2 x 3/16

## DIMENSIONS [INCHES]

Size	A	B	C	D*	M*	P	Q	Holes	
								No.	Dia.
144	10 3/4	10 3/8	3/4	8 1/4	7 7/8	27/16	-	12	7/16
174	12 5/8	12	3/4	10 1/8	9 1/2	-	-	12	7/16
194	13 1/8	12 3/4	7/8	10 7/8	9 3/4	-	-	12	7/16
224	16	13 3/4	7/8	13	10 3/4	-	3 3/8	16	7/16
264	18	15 3/8	7/8	15	12 3/8	-	-	16	7/16
294	19 7/8	17	7/8	16 7/8	14	-	-	16	7/16
334	21 3/4	18 5/8	7/8	18 3/4	15 5/8	25/16	-	20	7/16
364	23 3/4	20 1/4	7/8	20 3/4	17 1/4	-	37/32	24	7/16
404	26 7/8	23	1 1/8	22 7/8	19	-	-	24	9/16
454	29 3/4	25 3/8	1 1/8	25 3/4	21 3/8	-	-	24	9/16
504	32 3/4	27 7/8	1 1/8	28 3/4	23 7/8	27/16	3 1/2	32	9/16
574	36 5/8	31 1/8	1 1/8	32 5/8	27 1/8	-	-	32	9/16
644	40 5/8	34 1/2	1 1/8	36 5/8	30 1/2	1 3/4	37/16	40	9/16
714	44 3/8	37 5/8	1 1/8	40 3/8	33 5/8	35/16	-	40	9/16
784	48 3/8	40 7/8	1 1/8	44 3/8	36 7/8	-	35/16	44	9/16
854	52 1/4	44 1/8	1 1/8	48 1/4	40 1/8	29/16	-	48	9/16

\*Dimension shown is inside flange, outside outlet. Deduct housing material thickness to determine inside dimension of discharge.

**SERIES 20 ARRANGEMENTS 1, 9, AND 9E**

**SIZES 144-364**

**SERIES 30 ARRANGEMENTS 1 AND 9**

**SIZES 144-294**

**DIMENSIONS**

L, M, and D are outside dimensions.

J is from housing side over inlet collar.

Tolerance:  $\pm 1/8"$

Dimensions not to be used for construction unless certified.

Refer to page 7 for Arrangement 9, 9E and 9F motor limits.

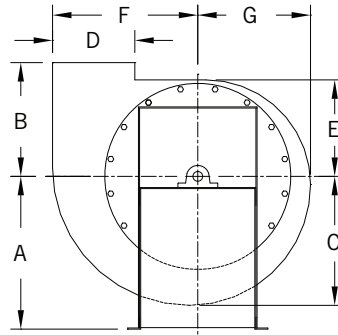
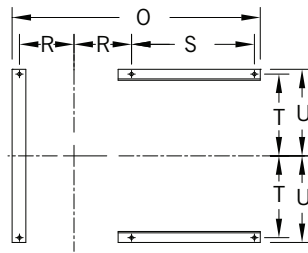
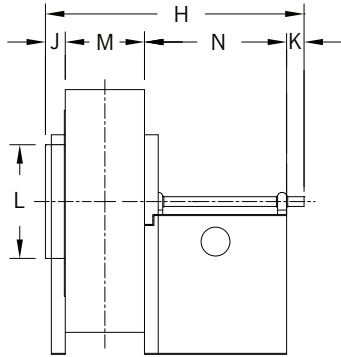

**SERIES 20 ARR. 1, 9, AND 9E SIZES 144-364 – DIMENSIONS [INCHES]**

Size	A	H		K	N		O		R	S		T	U	Base Holes
		Arr. 1, 9	Arr. 9E		Arr. 1, 9	Arr. 9E	Arr. 1, 9	Arr. 9E		Arr. 1, 9	Arr. 9E			
144	15 1/2	24	29 1/8	3 1/2	11	16 1/8	21	26 1/8	5 1/8	8 3/4	13 7/8	8 5/8	9 1/2	9/16
174	17 1/2	29 1/8	33 7/8	4	14	18 3/4	25 5/8	30 3/8	5 7/8	11 3/4	16 1/2	9 3/8	10 1/4	9/16
194	21 1/4	34 7/8	36 7/8	4 1/2	17 1/2	19 1/2	29 3/8	31 3/8	6	15 1/4	17 1/4	9 3/8	10 1/4	9/16
224	25 1/2	37 3/8	42 3/8	5	18 1/2	23 1/2	31 3/8	36 3/8	6 1/2	16 1/4	21 1/4	10 7/8	11 3/4	9/16
264	28	43 1/2	48 1/2	5 1/2	21 1/2	26 1/2	37	42	7 7/8	18 1/4	23 1/4	12 1/4	13 1/8	3/4
294	32 1/2	48 1/8	50 5/8	6	24	26 1/2	41 1/8	43 5/8	8 5/8	20 3/4	23 1/4	13 5/8	14 1/2	3/4
334	32 3/4	51 3/4	54 3/4	6 1/2	25 1/2	28 1/2	44 1/4	47 1/4	9 1/2	22 1/4	25 1/4	15 3/8	16 5/8	3/4
364	36 1/4	58	-	7	28 1/2	-	50	-	10 7/8	24	-	16 1/2	17 3/4	3/4

**SERIES 30 ARR. 1 AND 9 SIZES 144-294 – DIMENSIONS [INCHES]**

Size	A	H	K	N	O	R	S	T	U	Base Holes
144	15 7/8	24	3 1/2	11	21	5 1/8	8 3/4	8 5/8	9 1/2	9/16
174	18	29 1/8	4	14	25 5/8	5 7/8	11 3/4	9 3/8	10 3/8	9/16
194	21 1/4	40 1/2	4 1/2	23	34 7/8	6	20 7/8	9 3/8	10 1/4	9/16
224	25 1/2	44 5/8	5	25 1/2	39 3/8	7	22 3/8	10 7/8	11 3/4	9/16
264	28	49 3/4	5 1/2	27 1/2	44	8 3/8	23 3/8	12 1/4	13 1/8	3/4
294	32 1/2	51 7/8	6	27 1/2	45 5/8	9 1/8	23 3/8	13 5/8	14 1/2	3/4

\* See Page 8 for Arrangement 8 motor pedestal dimensions.

# SERIES 20 ARRANGEMENTS 1, 9, AND 9F

## SIZES 404-574

# SERIES 30 ARRANGEMENTS 1, 9, AND 9F

## SIZES 334-454

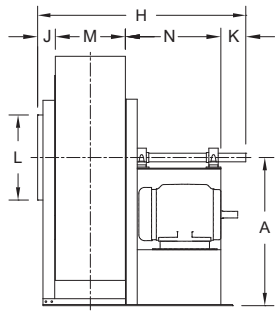

Base for all discharges except Down Blast.

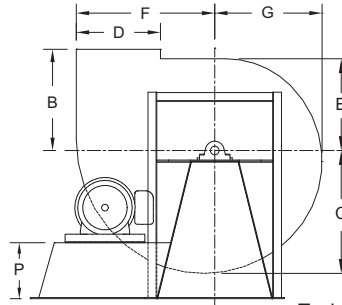
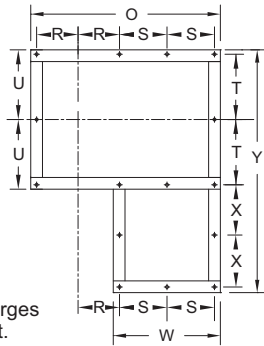

Typical Down Blast base shown CCW.

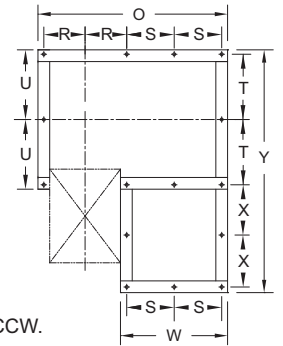

### SERIES 20 ARR. 1, 9, AND 9F SIZES 404-574 – DIMENSIONS [INCHES]

Size	A	H		K	N		O		P	R	S		T	U	Arr. 9F			Base Holes
		Arr. 1, 9	Arr. 9F		Arr. 1, 9	Arr. 9F	Arr. 1, 9	Arr. 9F			Arr. 1, 9	Arr. 9F			W	X	Y	
404	40	59 <sup>3</sup> / <sub>4</sub>	65	7 <sup>1</sup> / <sub>4</sub>	28 <sup>1</sup> / <sub>4</sub>	33 1/2	55 <sup>1</sup> / <sub>4</sub>	60 <sup>1</sup> / <sub>2</sub>	13 <sup>1</sup> / <sub>2</sub>	11 <sup>5</sup> / <sub>8</sub>	14	16 <sup>5</sup> / <sub>8</sub>	18 <sup>3</sup> / <sub>8</sub>	20 <sup>5</sup> / <sub>8</sub>	37 <sup>1</sup> / <sub>4</sub>	17	75 <sup>1</sup> / <sub>8</sub>	7/8
454	45	64 <sup>5</sup> / <sub>8</sub>	68 <sup>7</sup> / <sub>8</sub>	7 <sup>3</sup> / <sub>4</sub>	30 <sup>1</sup> / <sub>4</sub>	34 1/2	59 <sup>5</sup> / <sub>8</sub>	63 <sup>7</sup> / <sub>8</sub>	15	12 <sup>7</sup> / <sub>8</sub>	15	17 <sup>1</sup> / <sub>8</sub>	20 <sup>1</sup> / <sub>4</sub>	22 <sup>1</sup> / <sub>2</sub>	38 <sup>1</sup> / <sub>4</sub>	17	78 <sup>7</sup> / <sub>8</sub>	7/8
504	50 <sup>1</sup> / <sub>2</sub>	70 <sup>7</sup> / <sub>8</sub>	74 <sup>5</sup> / <sub>8</sub>	8 <sup>1</sup> / <sub>2</sub>	32 <sup>3</sup> / <sub>4</sub>	36 3/4	64 <sup>5</sup> / <sub>8</sub>	68 <sup>3</sup> / <sub>8</sub>	17	14 <sup>1</sup> / <sub>8</sub>	16 <sup>1</sup> / <sub>4</sub>	18 <sup>1</sup> / <sub>8</sub>	22 <sup>1</sup> / <sub>4</sub>	23 <sup>3</sup> / <sub>4</sub>	40 <sup>1</sup> / <sub>4</sub>	18 <sup>1</sup> / <sub>2</sub>	84 <sup>1</sup> / <sub>2</sub>	1
574	57 <sup>1</sup> / <sub>2</sub>	77 <sup>3</sup> / <sub>8</sub>	80 <sup>3</sup> / <sub>8</sub>	8 <sup>3</sup> / <sub>4</sub>	34 <sup>1</sup> / <sub>2</sub>	37 3/4	71 <sup>5</sup> / <sub>8</sub>	74 <sup>5</sup> / <sub>8</sub>	19	16 <sup>1</sup> / <sub>4</sub>	17 <sup>1</sup> / <sub>8</sub>	18 <sup>5</sup> / <sub>8</sub>	25	27 <sup>3</sup> / <sub>8</sub>	42 <sup>1</sup> / <sub>4</sub>	18 <sup>1</sup> / <sub>2</sub>	91 <sup>3</sup> / <sub>4</sub>	1

### SERIES 30 ARR. 1, 9, AND 9F SIZES 334-454 – DIMENSIONS [INCHES]

Size	A	H		K	N		O		P	R	S		T	U	Arr. 9F			Base Holes
		Arr. 1, 9	Arr. 9F		Arr. 1, 9	Arr. 9F	Arr. 1, 9	Arr. 9F			Arr. 1, 9	Arr. 9F			W	X	Y	
334	32 <sup>3</sup> / <sub>4</sub>	52 <sup>1</sup> / <sub>2</sub>	61	6 <sup>1</sup> / <sub>2</sub>	26	34 <sup>1</sup> / <sub>2</sub>	49 <sup>3</sup> / <sub>4</sub>	58 <sup>1</sup> / <sub>4</sub>	11	9 <sup>7</sup> / <sub>8</sub>	13	17 <sup>1</sup> / <sub>4</sub>	15 <sup>7</sup> / <sub>8</sub>	17 <sup>5</sup> / <sub>8</sub>	38 <sup>1</sup> / <sub>2</sub>	17	69 <sup>1</sup> / <sub>4</sub>	3/4
364	36 <sup>1</sup> / <sub>4</sub>	56 <sup>1</sup> / <sub>4</sub>	65	7	26 <sup>1</sup> / <sub>2</sub>	35 <sup>1</sup> / <sub>4</sub>	54	62 <sup>3</sup> / <sub>4</sub>	12	11 <sup>1</sup> / <sub>4</sub>	13 <sup>1</sup> / <sub>4</sub>	17 <sup>5</sup> / <sub>8</sub>	17 <sup>1</sup> / <sub>2</sub>	19 <sup>3</sup> / <sub>4</sub>	40 <sup>1</sup> / <sub>4</sub>	17	73 <sup>1</sup> / <sub>2</sub>	7/8
404	40	60 <sup>1</sup> / <sub>2</sub>	69 <sup>1</sup> / <sub>4</sub>	7 <sup>1</sup> / <sub>2</sub>	28 <sup>1</sup> / <sub>2</sub>	37 <sup>1</sup> / <sub>4</sub>	57 <sup>3</sup> / <sub>4</sub>	66 <sup>1</sup> / <sub>2</sub>	13 <sup>1</sup> / <sub>2</sub>	12 <sup>1</sup> / <sub>8</sub>	14 <sup>1</sup> / <sub>4</sub>	18 <sup>5</sup> / <sub>8</sub>	19 <sup>3</sup> / <sub>8</sub>	21 <sup>5</sup> / <sub>8</sub>	42 <sup>1</sup> / <sub>4</sub>	18 <sup>1</sup> / <sub>2</sub>	80 <sup>1</sup> / <sub>8</sub>	7/8
454	45	65 <sup>3</sup> / <sub>8</sub>	72 <sup>1</sup> / <sub>8</sub>	8	30 <sup>1</sup> / <sub>2</sub>	37 <sup>1</sup> / <sub>4</sub>	62 <sup>1</sup> / <sub>8</sub>	68 <sup>7</sup> / <sub>8</sub>	15	13 <sup>3</sup> / <sub>8</sub>	15 <sup>1</sup> / <sub>8</sub>	18 <sup>1</sup> / <sub>2</sub>	21 <sup>1</sup> / <sub>4</sub>	23 <sup>1</sup> / <sub>2</sub>	42 <sup>1</sup> / <sub>4</sub>	18 <sup>1</sup> / <sub>2</sub>	83 <sup>7</sup> / <sub>8</sub>	7/8

\* See Page 8 for Arrangement 8 motor pedestal dimensions.

# SERIES 20 ARRANGEMENTS 1 AND 9

# SIZES 644-854

# SERIES 30 ARRANGEMENTS 1 AND 9

# SIZES 504-644

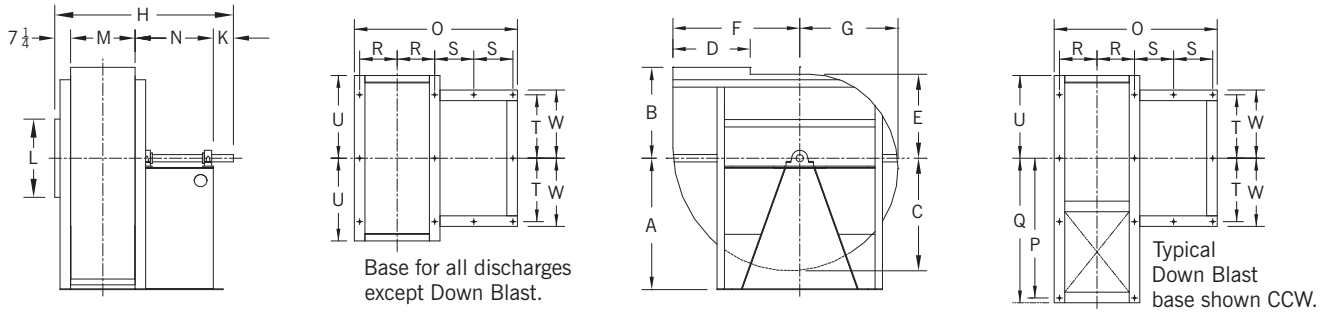

## SERIES 20 ARR. 1 AND 9 SIZES 644-854 – DIMENSIONS [INCHES]

Size	A							H	K	N	O	P	Q	R	S	T	U	W	Base Holes
	TH	BH	UB	DB	TAD	BAU	TAU												
644	49	64½	55½	43	45	59	52	84¼	9½	37	77½	62⅝	65½	17¾	18½	30	39⅛	32¼	1
714	54	71	61½	47½	50	65	57½	90⅞	10	40	83¼	68⅞	71⅜	19⅜	20	33½	43½	35¾	1
784	59	77	67	52	54¾	71	63	98⅝	10½	44	90½	75½	78	21	22	36½	47	38¾	1
854	64	83	73	57	60	78½	69	106⅜	11	48	97¾	82	84½	22⅝	24	39½	50½	41¾	1

## SERIES 30 ARR. 1 AND 9 SIZES 504-644 – DIMENSIONS [INCHES]

Size	A	H	K	N	O	P	Q	R	S	T	U	Base Holes
504	50½	71⅛	8½	32½	64⅜	49¼	51¼	14	16¼	22¼	31⅜	1
574	57½	77⅝	9	34¼	71⅜	56⅛	58⅝	16⅛	17⅛	25	35¾	1
644	64	84½	9½	37	77½	62⅝	65½	17¾	18½	30	39⅛	1

\* See Page 8 for Arrangement 8 motor pedestal dimensions.

# SERIES 30 ARRANGEMENTS 1 AND 9

# SIZES 714-854

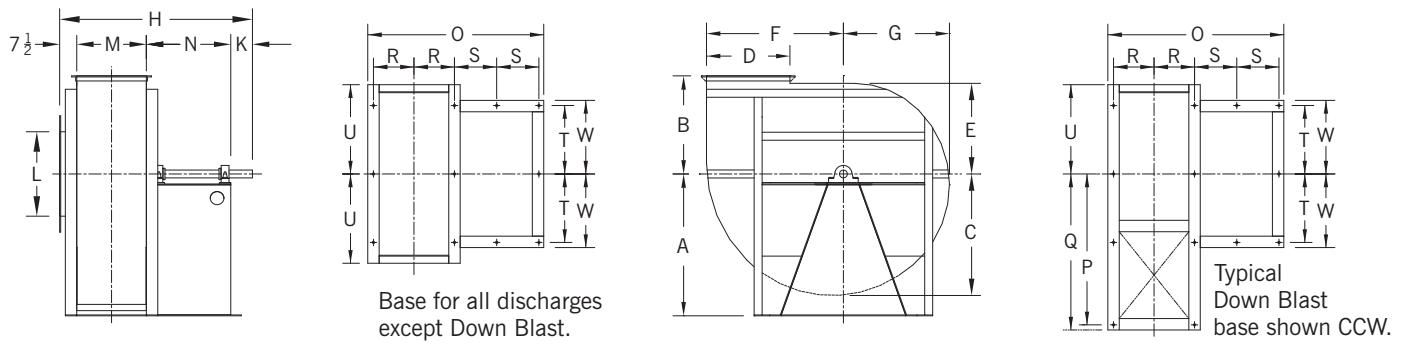

## SERIES 30 ARR. 1 AND 9 SIZES 714-854 – DIMENSIONS [INCHES]

Size	A							H	K	N	O	P	Q	R	S	T	U	W	Base Holes
	TH	BH	UB	DB	TAD	BAU	TAU												
714	54	71	61½	47½	50	65	57½	91⅛	10	40	83¼	69	71½	19⅜	20	33½	43½	35¾	1
784	59	77	67	52	54¾	71	63	98⅞	10½	44	90½	75½	78	21	22	36½	47	38¾	1
854	64	83	73	57	60	78½	69	106⅜	11	48	97¾	82	84½	22⅝	24	39½	50½	41¾	1

\* See Page 8 for Arrangement 8 motor pedestal dimensions.

# DIMENSIONS ARRANGEMENT 4

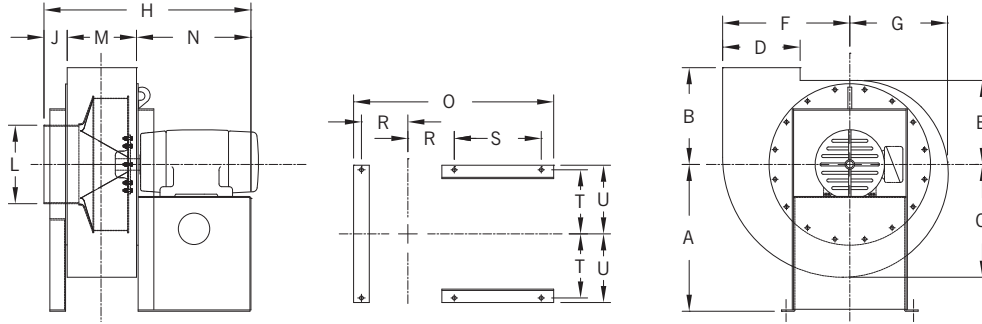

## SERIES 20 SIZES 144-364 AND SERIES 30 SIZES 194-364 ARR. 4 – DIMENSIONS [INCHES]

Size	A	R		T		U		Base Holes
		Ser. 20	Ser. 30	Ser. 20	Ser. 30	Ser. 20	Ser. 30	
144	15½	6¼/16	–	8⅝	–	9½	–	9/16
174	17½	6⅞	–	9¾	–	10¼	–	9/16
194	21¼	7		9¾		10¼		9/16
224	25½	7½		10⅞		11¾		9/16
264	28	8⅝/16		12¼		13⅞		¾
294	32½	9⅞		13⅝		14½		¾
334	32¾	9⅝/16		15¾	15⅞	16⅝	17⅝	¾
364	36¼	10¼/16	11⅝/16	16½	17½	17¾	19¾	7/8

## SERIES 20 SIZES 144-364 AND SERIES 30 SIZES 194-364 ARR. 4 – DIMENSIONS [INCHES]

Size	Motor Frame	H*		N		O		S	
		Ser. 20	Ser. 30	Ser. 20	Ser. 30	Ser. 20	Ser. 30	Ser. 20	Ser. 30
144	143/5	21	–	11½	–	21¼	–	7⅞	–
	182/4	22		12½		22¼		8⅞	
	213/5	24¼		14¾		24½		10¾	
174	182/4	23⅝	–	12½	–	23⅞	–	8⅞	–
	213/5	25⅞		14¾		26⅞		10¾	
	254/6	29⅝		18½		29⅞		14⅞	
	284/6	31⅞		20		31⅞		15⅝	
194	182/4	25¾	–	12½	–	24⅞	–	8⅞	–
	213/5	27⅝	27⅞	14¾	–	26¾	–	10¾	–
	254/6	31¾	31⅝	18½	–	30⅞	–	14⅞	–
	284/6	32⅞	33⅞	20	–	31⅝	–	15⅝	–
224	324/6	34¾	34⅝	21½	–	33⅞	–	17⅞	–
	182/4	26¾	–	12½	–	25⅞	–	8⅞	–
	213/5	28⅝	28⅞	14¾	–	27⅞	28¾	10¾	–
	254/6	32¾	32⅝	18½	–	31⅞	32⅞	14⅞	–
264	284/6	33⅞	34⅞	20	–	32⅝	33⅝	15⅝	–
	324/6	35¾	35⅝	21½	–	34⅞	35⅞	17⅞	–
	213/5	31¼	31½	14¾	–	30	31	10¾	–
	254/6	35	35¼	18½	–	33¾	34¾	14⅞	–
294	284/6	36½	36¾	20	–	35¼	36¼	15⅝	–
	324/6	38	38¼	21½	–	36¾	37¾	17⅞	–
	364/5	–	39½	–	22¾	–	38½	–	17⅞
	254/6	36⅝	36⅞	18½	–	35¾	36¾	14⅞	–
334	284/6	38⅞	38¾	20	–	36⅞	37⅞	15⅝	–
	324/6	39⅝	39⅞	21½	–	38¾	39¾	17⅞	–
	364/5	–	40¾	–	22¾	–	40⅞	–	17⅞
	284	39¾	37⅝	20	17⅝	38¾	41⅞	15⅝	8⅞
286	39⅞		19⅞		42⅝		9⅞		
364	324	41¼	40¾	21½	20¾	40¼	43¾	17⅞	9⅝/16
	326		41⅞		21⅞		45¼		10⅝/16
	364	42⅞	41¼	22¾	21¼	41⅞	41	17⅞	8⅞/16
	365		42¼		22¼		42		9⅝/16
364	404	44¾	43⅞	24⅝	23⅞	43¾	42⅞	20⅞	9½
	405		44⅝		24⅝		44¾		10¼
	284	42⅞/16	40¾	20¼/16	17⅞	41½	44¾	15⅝	8⅞/16
	286		41⅞		19⅞		46¼		9⅝/16
	324	44¼/16	43⅞	21⅞/16	20¾	43	47¾	17⅞	9⅞
	326		44⅝		21⅞		48⅞		10⅝
	364	44⅝/16	44	22⅞/16	21¼	43⅞	43⅝/16	17⅞	8⅝/32
365	45		22¼		44⅝/16		8⅝/32		
404	47¾/16	45⅞	24⅝/16	23⅞	46⅞	45⅞/16	20⅞	8⅝/32	
405		47¾		24⅝		47⅝/16		9⅝/32	

\* H is with slip inlet for Series 20, and flanged inlet for Series 30