

SIZES 80/89 SINGLE WIDTH ACOUSTAFOIL/PLR FANS

The Single-Width AcF/PLR Fan line has been extended to Sizes 80 and 89. They are typically used for: air-drying, product cooling, product drying, combustion air, supply and exhaust, fume control and on the clean-air side of dust collection systems.

APPLICATIONS

With four classes to choose from, the Single-Width AcF/PLR Fans are ideally suited for a wide range of clean-air applications. They are typically used for: air-drying, product cooling, product drying, combustion air, supply and exhaust, fume control and on the clean-air side of dust collection systems.

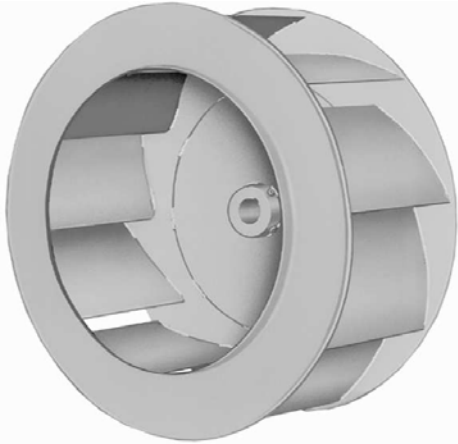

AcoustaFoil Wheel

DESIGN FEATURES

- Two sizes . . . 80 & 89.
- Pressures up to 20" WG.
- Capacities to 300,000 CFM.
- Maximum temperature of 1000°F.
- Efficiencies beyond 88%.
- Choice of AcoustaFoil or PLR wheels.
- Unique inlet cone with airflow diverter improves fan efficiency.
- Standard construction includes split housing.

CONSTRUCTION FEATURES

Welded construction - heavy-gauge welded components provide structural strength and durability for extended service life in a wide range of applications.

Housing - continuously welded for the strongest possible construction.

Precision balancing - all AcoustaFoil and PLR wheels are dynamically balanced before final assembly. After assembly, all fans are fine-tune balanced on a rigid test fixture at the specified running speed.

Finish - two-coat paint system consisting of one prime coat and one finish coat of **nyb** green air-dried enamel.

Lifting eyes - standard on all models . . . sized and located for ease of handling.

Optional accessories - numerous fan accessories are available to meet application requirements including: motors, variable frequency drives [VFDs], inlet and outlet guards, flanged inlets and outlets, drains, cleanout doors and more. Consult your New York Blower representative for a complete list.

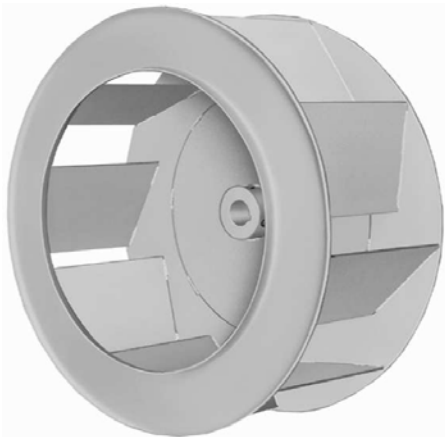

PLR Wheel



THE NEW YORK BLOWER COMPANY
7660 Quincy Street
Willowbrook, IL 60527-5530

Visit us on the Web: <http://www.nyb.com>
Phone: (800) 208-7918 Email: nyb@nyb.com

AcoustaFoil/PLR ACF CAPACITY TABLES

The New York Blower Company certifies that the Single-Width AcoustaFoil Fans shown are licensed to bear the AMCA Seal. The ratings shown are based on tests and procedures performed in accordance with AMCA Publication 211 and comply with the requirements of the AMCA Certified Ratings Program.

Size 80 Class 1-3 Inlet Diameter: 4.27 ft. Wheel Diameter: 80.75 in Outlet Area: 37.45 ft²

CFM	OV	1"SP		2"SP		3"SP		4"SP		6"SP		8"SP		10"SP		12"SP		14"SP	
		RPM	BHP	RPM	BHP	RPM	BHP	RPM	BHP	RPM	BHP	RPM	BHP	RPM	BHP	RPM	BHP	RPM	BHP
60,000	1602	272	13	326	23	379	34.5	430	47.6	522	76.6	605	110	679	145	745	183	805	222
77,000	2056	322	20.1	364	31.7	406	44.4	447	58.5	528	90.3	604	125	675	165	739	205	803	252
94,000	2510	375	29.7	410	43.5	445	57.9	479	73	547	107	613	144	679	187	740	230	798	277
111,000	2964	430	42.3	462	59	491	75	520	92	577	128	636	169	693	212	747	258	802	308
128,000	3418	486	58.4	514	77.7	541	96.7	567	116	618	156	668	198	717	243	766	291	815	343
145,000	3872	543	78.7	569	101	593	122	616	144	661	187	705	233	751	282	794	332	837	384
162,000	4326	601	103	624	129	646	153	667	176	709	225	749	274	789	325	828	379	868	434
179,000	4780	659	133	680	161	701	188	721	215	759	268	795	320	831	374	868	433		

Size 89 Class 1-3 Inlet Diameter: 4.71 ft. Wheel Diameter: 89 in Outlet Area: 45.40 ft²

CFM	OV	1"SP		2"SP		3"SP		4"SP		6"SP		8"SP		10"SP		12"SP		14"SP	
		RPM	BHP	RPM	BHP	RPM	BHP	RPM	BHP	RPM	BHP	RPM	BHP	RPM	BHP	RPM	BHP	RPM	BHP
75,000	1652	251	16.6	299	28.8	345	42.8	391	58.8	474	94.6	550	136	617	180	675	225	731	274
92,000	2026	288	23.6	328	37.7	366	53	404	69.9	479	108	549	152	613	198	672	249	728	302
109,000	2401	328	32.9	361	48.9	394	65.8	427	84.4	491	125	553	169	614	219	672	273	724	328
126,000	2775	368	44.3	398	62.9	427	81.5	455	102	511	144	568	193	622	244	675	299	726	358
143,000	3150	410	58.6	437	80	463	101	488	122	538	168	587	218	637	273	685	330	731	389
160,000	3524	452	75.9	477	100	501	124	524	148	568	196	612	249	656	305	701	365	745	430
177,000	3899	495	96.6	518	124	540	150	561	176	601	228	642	285	682	343	721	404		
194,000	4273	538	121	560	151	580	181	599	208	637	266	674	325	710	386	746	451		

Size 80 Class 4 Inlet Diameter: 4.27 ft. Wheel Diameter: 80.75 in Outlet Area: 37.45 ft²

CFM	OV	10"SP		11"SP		12"SP		13"SP		14"SP		15"SP		16"SP		17"SP		18"SP		20"SP	
		RPM	BHP	RPM	BHP	RPM	BHP	RPM	BHP	RPM	BHP	RPM	BHP	RPM	BHP	RPM	BHP	RPM	BHP	RPM	BHP
95,000	2537	681	189	710	209	741	233	772	257	799	280	828	305	854	329	883	357	909	383	956	433
103,000	2750	684	199	714	221	745	247	771	268	799	292	828	320	853	343	879	370	907	399	954	451
111,000	2964	692	212	720	234	750	260	776	283	802	307	830	334	856	361	880	386	906	414	953	469
119,000	3178	704	227	730	250	756	274	784	300	808	325	834	351	859	377	884	406	908	434	957	492
127,000	3391	715	241	740	265	767	291	791	316	817	343	839	367	864	397	886	422	911	453	957	510
135,000	3605	729	257	753	282	777	308	800	333	825	361	848	388	870	415	893	444	918	475	960	532
143,000	3818	746	276	768	301	791	328	814	354	835	380	857	408	879	435	901	464	924	496	968	558
151,000	4032	762	295	784	321	806	349	826	374	847	401	869	430	892	461	910	488	933	520		
159,000	4246	781	316	801	342	821	369	843	398	863	426	882	454	902	482	922	513	941	542		

Size 89 Class 4 Inlet Diameter: 4.71 ft. Wheel Diameter: 89 in Outlet Area: 45.40 ft²

CFM	OV	10"SP		11"SP		12"SP		13"SP		14"SP		15"SP		16"SP		17"SP		18"SP		20"SP	
		RPM	BHP	RPM	BHP	RPM	BHP	RPM	BHP	RPM	BHP	RPM	BHP	RPM	BHP	RPM	BHP	RPM	BHP	RPM	BHP
125,000	2753	621	242	648	269	675	298	701	327	726	357	750	387	776	420	800	452	822	483	865	547
132,000	2907	627	253	652	281	678	309	702	338	726	368	752	400	776	433	799	465	823	499	868	568
139,000	3062	633	266	658	294	683	323	706	352	729	381	754	414	777	446	801	482	824	516	867	583
146,000	3216	640	278	664	306	687	336	710	365	735	398	758	431	780	463	804	498	822	527	869	604
153,000	3370	648	291	671	321	694	350	716	381	740	414	760	443	784	479	803	510	827	548	869	618
160,000	3524	656	304	678	334	700	364	722	395	745	429	766	462	787	494	809	530	829	563	871	638
167,000	3678	666	320	687	349	709	381	729	412	749	443	773	480	793	513	814	549	833	582	874	658
174,000	3833	677	336	697	366	718	399	739	432	758	463	779	498	798	531	819	567	837	601	877	677
181,000	3987	689	354	708	385	728	416	746	447	767	483	785	515	804	548	823	585	844	624		

PLR CAPACITY TABLES

The New York Blower Company certifies that the Single-Width AcoustaFoil Fans shown are licensed to bear the AMCA Seal. The ratings shown are based on tests and procedures performed in accordance with AMCA Publication 211 and comply with the requirements of the AMCA Certified Ratings Program.

Size 80 Class 1-3 Inlet Diameter: 4.27 ft. Wheel Diameter: 80.75 in Outlet Area: 37.45 ft²

CFM	OV	1"SP		2"SP		3"SP		4"SP		6"SP		8"SP		10"SP		12"SP		14"SP	
		RPM	BHP	RPM	BHP	RPM	BHP	RPM	BHP	RPM	BHP	RPM	BHP	RPM	BHP	RPM	BHP	RPM	BHP
65,000	1736	260	15.7	312	27	362	40.1	412	55.7	502	91.7	578	132	650	179	713	229	771	282
78,000	2083	293	21.8	336	34.2	379	48.3	421	63.9	504	101	578	143	645	189	711	243	768	297
91,000	2430	328	29.6	365	43.5	402	58.6	439	75.4	511	112	581	156	646	203	707	256	766	314
104,000	2777	364	39.4	398	55.1	430	71.5	463	89.4	526	128	590	172	652	222	709	274	766	333
117,000	3124	402	51.4	432	69.1	461	86.9	489	105	547	147	604	192	660	242	713	295	767	354
130,000	3471	439	65.7	467	85.4	494	105	520	125	571	168	622	215	674	266	725	322	774	381
143,000	3818	478	82.9	504	105	528	126	552	148	599	194	645	242	693	296	740	352		
156,000	4166	516	103	541	127	564	151	586	174	629	222	671	273	714	328	757	386		

Size 89 Class 1-3 Inlet Diameter: 4.71 ft. Wheel Diameter: 89 in Outlet Area: 45.40 ft²

CFM	OV	1"SP		2"SP		3"SP		4"SP		6"SP		8"SP		10"SP		12"SP		14"SP	
		RPM	BHP	RPM	BHP	RPM	BHP	RPM	BHP	RPM	BHP	RPM	BHP	RPM	BHP	RPM	BHP	RPM	BHP
100,000	2203	276	29.4	313	45	350	62.6	386	81.7	459	127	525	178	586	235	645	301	694	365
111,000	2445	298	36.2	332	53.3	366	71.9	399	91.9	464	137	528	190	587	248	643	313	693	379
122,000	2687	321	44.3	353	62.7	383	82.1	413	103	473	150	532	203	588	262	644	329	693	395
133,000	2930	345	53.5	374	73.7	402	94.5	429	116	485	165	540	219	594	280	646	345	695	415
144,000	3172	368	64.2	396	86.2	422	108	447	131	499	181	550	237	600	296	650	364	698	436
155,000	3414	392	76.3	418	99.7	443	123	466	147	514	199	561	255	608	317	656	385	701	457
166,000	3656	416	90.1	441	115	464	140	486	166	530	219	575	278	620	341	663	408		
177,000	3899	441	106	464	132	486	159	507	185	549	242	591	302	632	367	674	437		

Size 80 Class 4 Inlet Diameter: 4.27 ft. Wheel Diameter: 80.75 in Outlet Area: 37.45 ft²

CFM	OV	10"SP		11"SP		12"SP		13"SP		14"SP		15"SP		16"SP		17"SP		18"SP		20"SP	
		RPM	BHP	RPM	BHP	RPM	BHP	RPM	BHP	RPM	BHP	RPM	BHP	RPM	BHP	RPM	BHP	RPM	BHP	RPM	BHP
100,000	2670	649	216	680	243	709	269	736	296	766	327	790	354	817	385	845	420	866	448	918	520
112,500	3004	657	234	684	260	712	288	739	316	768	349	794	378	817	407	842	439	868	475	913	540
125,000	3338	669	258	695	284	720	312	748	342	772	371	797	402	821	434	847	469	867	498	915	569
137,500	3672	685	283	709	311	733	339	756	367	780	398	804	430	829	464	849	494	871	526	917	600
150,000	4005	704	313	725	340	748	369	772	402	793	431	815	463	836	494	857	527	880	564	923	636
162,500	4339	728	347	748	377	768	406	789	437	809	468	830	501	850	533	870	567	889	599	929	671
175,000	4673	753	385	772	415	791	446	810	476	829	509	849	544	868	578	885	609	906	647	941	716
187,500	5007	781	428	797	457	816	491	833	520	851	556	869	589	887	624	904	657	921	692	958	769
200,000	5340	808	472	825	504	842	538	858	570	875	604	892	640	910	678	926	713	943	750		

Size 89 Class 4 Inlet Diameter: 4.71 ft. Wheel Diameter: 89 in Outlet Area: 45.40 ft²

CFM	OV	10"SP		11"SP		12"SP		13"SP		14"SP		15"SP		16"SP		17"SP		18"SP		20"SP	
		RPM	BHP	RPM	BHP	RPM	BHP	RPM	BHP	RPM	BHP	RPM	BHP	RPM	BHP	RPM	BHP	RPM	BHP	RPM	BHP
130,000	2863	593	275	620	308	644	339	670	374	695	411	719	447	742	484	766	524	788	563	831	647
145,000	3194	601	299	627	333	649	364	675	401	697	436	722	475	742	509	766	553	786	589	831	679
160,000	3524	615	329	637	362	660	396	681	431	702	465	727	508	748	546	770	587	791	628	832	714
175,000	3855	629	360	650	395	672	430	694	469	714	504	734	543	754	580	774	621	796	666	834	749
190,000	4185	649	399	670	437	688	471	708	508	726	545	746	584	764	622	783	664	804	709	842	798
205,000	4515	672	445	689	479	707	516	724	552	744	595	761	632	778	672	797	715	816	761	849	844
220,000	4846	695	492	712	530	728	566	745	605	762	647	779	686	796	728	811	768	827	809	861	901
235,000	5176	720	546	736	583	752	623	766	660	783	705	799	748	814	787	829	829	845	873	875	962
250,000	5507	746	602	762	644	776	682	790	723	805	767	819	807	835	855	850	899	866	947		

AcoustaFoil/PLR SPEED DERATES

Temperature Derates for AcF/PLR Wheel Safe Speeds

Temperature	Mild Steel	316 SST	2205 SST
70°	1.00	0.64	0.85
120°	0.98	0.63	0.82
200°	0.97	0.61	0.79
300°	0.94	0.58	0.76
400°	0.91	0.56	0.73
500°	0.88	0.54	0.70
600°	0.85	0.53	0.68
700°	0.81	0.52	--
750°	0.79	0.51	--

AcoustaFoil/PLR MAX SAFE SPEED (at 70°F.)

Size	Wheel	Class			
		1	2	3	4
80	AcF	500	650	825	970
89		450	590	750	880
80	PLR	475	615	780	970
89		430	560	705	880

AcoustaFoil/PLR MATERIAL SPECIFICATIONS

Class 1

Size	Housing (All Arrangements)		Shaft		Bearings		Wheel				Bare Fan Weight (Less Wheel)	
							AcF		PLR			
	Scroll	Sides	Arr. 1	Arr. 3	Arr. 1	Arr. 3	WR ²	Weight	WR ²	Weight	Arr. 1	Arr. 3
80	1/4	1/4	4 7/16	3 15/16	G	F	13,170	2,050	10,870	1,800	8,135	6,199
89	1/4	1/4	4 15/16	3 15/16	G	F	19,180	2,420	15,630	2,100	9,779	7,246

Class 2

Size	Housing (All Arrangements)		Shaft		Bearings		Wheel				Bare Fan Weight (Less Wheel)	
							AcF		PLR			
	Scroll	Sides	Arr. 1	Arr. 3	Arr. 1	Arr. 3	WR ²	Weight	WR ²	Weight	Arr. 1	Arr. 3
80	1/4	1/4	4 7/16	3 15/16	G	F	13,170	2,050	10,870	1,800	8,818	6,164
89	1/4	1/4	4 15/16	3 15/16	G	F	19,180	2,420	15,630	2,100	10,646	7,246

Class 3

Size	Housing (All Arrangements)		Shaft				Bearings				Wheel			
											AcF		PLR	
	Scroll	Sides	Arr. 1	Arr. 3	Arr. 7	Arr. 8	Arr. 1	Arr. 3	Arr. 7	Arr. 8	WR ²	Weight	WR ²	Weight
80	1/4	1/4	5 7/16	4 15/16‡	4 7/16	5 7/16	G	F*	F*	G	13,170	2,050	10,870	1,800
89	1/4	1/4	5 7/16	4 15/16‡	4 7/16	5 7/16	G	F*	F*	G	19,180	2,420	15,630	2,100

‡ 3 15/16 at Inlet Bearing

Class 3 continued

Bare Fan Weight (Less Wheel)				
Size	Arr. 1	Arr. 3	Arr. 7	Arr. 8
80	9,356	6,509	PER JOB	
89	11,079	7,615		

Class 4

Size	Housing (All Arrangements)		Shaft		Bearings		Wheel				Bare Fan Weight (Less Wheel)	
							AcF		PLR			
	Scroll	Sides	Arr. 7	Arr. 8	Arr. 7	Arr. 8	WR ²	Weight	WR ²	Weight	Arr. 7	Arr. 8
80	1/4	1/4	4 15/16‡	5 7/16	F*	G	13,170	2,050	10,870	1,800	PER JOB	
89	1/4	1/4	4 15/16‡	6	F*	G	19,180	2,420	15,630	2,100		

‡ 3 15/16 at Inlet Bearing

F= Link-Belt P-B22400 Spherical Roller

F*= Link-Belt P-B22500 Spherical Roller

G= Link-Belt P-LB6800 Series Spherical Roller (or equivalent)

AcoustaFoil/PLR FLANGE DIMENSIONS

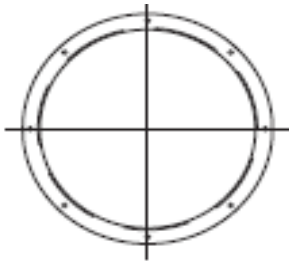

Flange Inlet Dimensions

Size	ID	BC	OD	Holes	
				Number	Diameter
80	88 5/8	90 7/8	92 5/8	32	9/16
89	97 5/8	99 7/8	101 5/8		

Holes furnished on vertical centerline.

Tolerance: $\pm \frac{1}{8}$

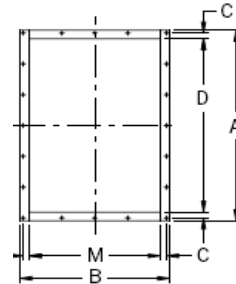

Flange Outlet Dimensions

1. Flange face mounted flush with outside edge of housing discharge.
2. Holes furnished on 4" centers from centerlines.

Size	A	B	C	D	M	Holes		
						Sides	Top/Bottom	Diameter
80	94	64 3/4	1 1/8	90	60 3/4	23	15	9/16
89	103	70 7/8		99	66 7/8	25	17	

Tolerance: $\pm \frac{1}{8}$

UNITARY BASE DIMENSIONS

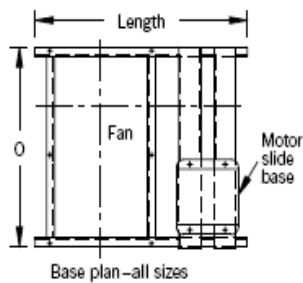
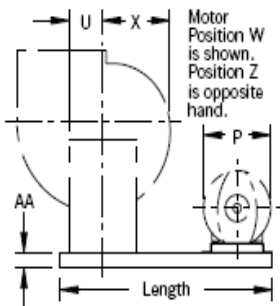

Approximate base length = $U + X + P + 16$

- U=from fan base dimension drawing.
- X=dimension from fan centerline to edge of scroll nearest motor. Dimensions varies with discharge and motor position.
- P=diameter of motor from table below.
- 16=constant – allows for motor clearance.

NOTE: These dimensions are only approximate. Exact dimensions furnished after order is placed.

Size	AA	O		
		Class 1	Class 2	Class 3
80	8	109 3/8	124 3/8	127 3/8
89		119 1/2	136 1/2	139 1/2

Tolerance: $\pm \frac{1}{8}$

Structural-steel channel base provides a factory designed package of Arrangement 1 or 3 fan, motor, drive, and guard. Also available with rubber-in-shear or spring isolation. Built-in motor rails provide for adjustment of belt tension.

Unitary base is also available for Arrangement 7 and 8 fans.

DIMENSIONS

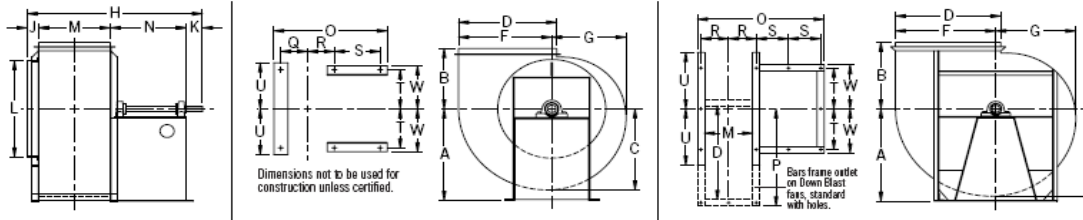

Class 1 & 2, Arrangement 1

Size	A				B		C	D	F	G	H	
	TH/TAD	BH/BAU	UB/TAU	DB	*	TAD					Class 1	Class 2
80	71	89	84	57	57	82	81 11/16	90	85 11/16	68 3/8	120 1/4	135 1/4
89	78	98	92 1/2	63	63	88	90 1/8	99	94 1/2	75 7/16	130 7/8	147 7/8

Size	J	K	L	M	N		O		P	R	S	
					Class 1	Class 2	Class 1	Class 2			Class 1	Class 2
80	7	10 1/2	89 1/2	60 3/4	42	57	112 3/8	127 3/8	88 1/4	32 7/8	20 13/16	28 5/16
89	11	98 1/2	66 7/8	66 7/8	46	63	122 1/2	139 1/2	97	35 15/16	22 13/16	31 5/16

Size	T	U	W	a	b		c	d	Base Holes
					BAU/TAU	TAD			
80	36 3/4	50	39 1/4	76 1/8	101	118 5/8	84 1/2	61	1
89	40 1/4	54 7/8	42 3/4	84	111 3/8	129	93 1/4	67 1/4	1

* For TH, BH, UB, DB, BAU and TAU discharge. J is from housing side over inlet collar. L, M, and D are outside dimensions. Tolerance: ±1/4"

Class 3, Arrangement 1 & 8

Size	A				B		C	D	F	G	H	J
	TH/TAD	BH/BAU	UB/TAU	DB	*	TAD						
80	71	89	84	57	57	82	81 11/16	90	85 11/16	68 3/8	138 3/4	7
89	78	98	92 1/2	63	63	88	90 1/8	99	94 1/2	75 7/16	151 3/8	7

Size	K	L	M	N	O	P	R	S	T	U	W	a
80	11	89 1/2	60 3/4	60	130 3/8	88 1/4	32 7/8	29 13/16	36 3/4	50	39 1/4	76 1/8
89	11 1/2	98 1/2	66 7/8	66	142 1/2	97	35 15/16	32 13/16	40 1/4	54 7/8	42 3/4	84

Size	b		c	d	Base Holes
	BAU/TAU	TAD			
80	101	118 5/8	84 1/2	61	1
89	111 3/8	129	93 1/4	67 1/4	1

* For TH, BH, UB, DB, BAU and TAU discharge. J is from housing side over inlet collar. L, M, and D are outside dimensions. Tolerance: ±1/4"

Class 4, Arrangement 8

Size	A				B		C	D	F	G	H	J
	TH/TAD	BH/BAU	UB/TAU	DB	*	TAD						
80	71	89	84	57	57	82	81 11/16	90	85 11/16	68 3/8	139 1/4	7
89	78	98	92 1/2	63	63	88	90 1/8	99	94 1/2	75 7/16	151 7/8	7

Size	K	L	M	N	O	P	R	S	T	U	W	a
80	11 1/2	89 1/2	60 3/4	60	130 3/8	88 1/4	32 7/8	29 13/16	36 3/4	50	39 1/4	76 1/8
89	12	98 1/2	66 7/8	66	142 1/2	97	35 15/16	32 13/16	40 1/4	54 7/8	42 3/4	84

Size	b		c	d	Base Holes
	BAU/TAU	TAD			
80	101	118 5/8	84 1/2	61	1
89	111 3/8	129	93 1/4	67 1/4	1

* For TH, BH, UB, DB, BAU and TAU discharge. J is from housing side over inlet collar. L, M, and D are outside dimensions. Tolerance: ±1/4"

FAN DISCHARGES – VIEWED FROM DRIVE SIDE

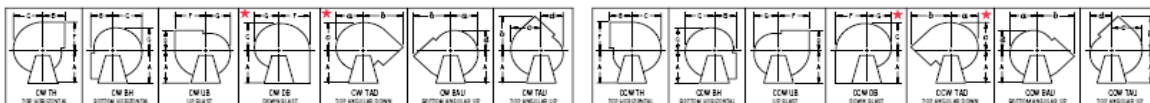

Clockwise—angular discharges at 45°

Counterclockwise—angular discharges at 45°

★ Down Blast and Top Angular Down discharge positions must be evaluated for clearance of accessories such as flanged outlet, outlet damper, unitary base, etc. Consult nyb with specific details.

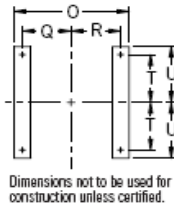
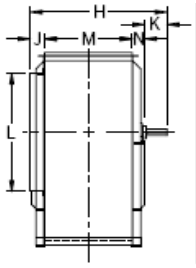

Dimensions not to be used for construction unless certified.

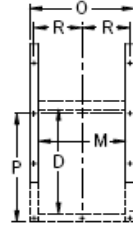
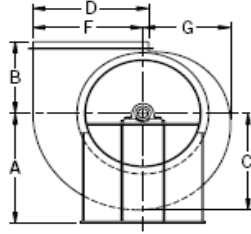

Bars frame outlet on Down Blast fans, standard with holes.

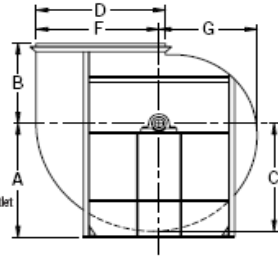

Class 1 & 2, Arrangement 3 / Class 3, Arrangement 3 & 7

Size	A			DB	B		C	D	F	G
	TH/TAD	BH/BAU	UB/TAU		*	TAD				
80	71	89	84	57	57	82	81 11/16	90	85 11/16	68 3/8
89	78	98	92 1/2	63	63	88	90 1/8	99	94 1/2	75 7/16

Size	H			J	K		L	M	N		
	Class 1	Class 2	Class 3		Class 1,2	Class 3			Class 1	Class 2	Class 3
80	87	1/4	87	9	10	11	89	60	7		
89	93	7/8	94		11	11 1/2	98	66			

Size	O	P	R	T	U	a	b		c	d	Base Holes
							BAU/TAU	TAD			
80	70 3/4	88 1/4	32 7/8	36 3/4	50	76 1/8	101	118 5/8	84 1/2	61	1
89	76 7/8	97	35 15/16	40 1/4	54 7/8	84	111 3/8	129	93 1/4	67 1/4	

* For TH, BH, UB, DB, BAU and TAU discharge. J is from housing side over inlet collar. L, M, and D are outside dimensions. Tolerance: ±1/16"

Class 4, Arrangement 7

Size	A				B		C	D	F	G	H
	TH/TAD	BH/BAU	UB/TAU	DB	*	TAD					
80	71	89	84	57	57	82	81 11/16	90	85 11/16	68 3/8	89 1/4
89	78	98	92 1/2	63	63	88	90 1/8	99	94 1/2	75 7/16	95 7/8

Size	J	K	L	M	N	O	P	R	T	U	a
80	9	11 1/2	89 1/2	60 3/4	8	70 3/4	88 1/4	32 7/8	36 3/4	50	76 1/8
89		12	98 1/2	66 7/8		76 7/8	97	35 15/16	40 1/4	54 7/8	84

Size	b		c	d	Base Holes
	BAU/TAU	TAD			
80	101	118 5/8	84 1/2	61	1
89	111 3/8	129	93 1/4	67 1/4	

* For TH, BH, UB, DB, BAU and TAU discharge. J is from housing side over inlet collar. L, M, and D are outside dimensions. Tolerance: ±1/16"

FAN DISCHARGES – VIEWED FROM DRIVE SIDE

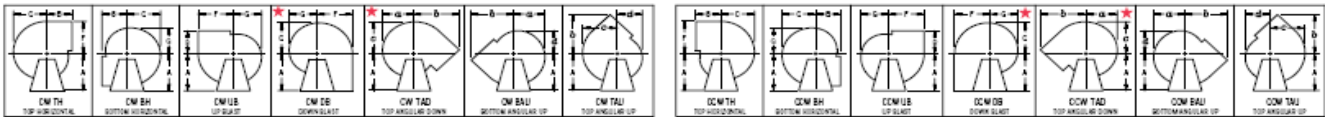

Clockwise—angular discharges at 45°

Counterclockwise—angular discharges at 45°

★ Down Blast and Top Angular Down discharge positions must be evaluated for clearance of accessories such as flanged outlet, outlet damper, unitary base, etc. Consult nyb with specific details.