



THE NEW YORK BLOWER COMPANY  
7660 Quincy Street  
Willowbrook, IL 60527-5530

Visit us on the Web: <http://www.nyb.com>  
Phone: (800) 208-7918 Email: [nyb@nyb.com](mailto:nyb@nyb.com)

INSTALLATION  
MAINTENANCE,  
OPERATING  
INSTRUCTIONS

IM-100

## CENTRIFUGAL FANS

AcF/PLR, AF, BC, BC Pressure Blowers, BC-2200, EcF Plenum, RTS, HPBC  
SOUND



Some fans can generate sound that could be hazardous to exposed personnel. It is the responsibility of the system designer and user to determine sound levels of the system, the degree of personnel exposure, and to comply with applicable safety requirements to protect personnel from excessive noise. Consult **nyb** for fan sound power level ratings.

### AIR PRESSURE AND SUCTION

In addition to the normal dangers of rotating machinery, fans present another hazard from the suction created at the fan inlet. This suction can draw materials into the fan where they become high velocity projectiles at the outlet. It can also be extremely dangerous to persons in close proximity to the inlet, as the forces involved can overcome the strength of most individuals. Inlets and outlets that are not ducted should be screened to prevent entry and discharge of solid objects.

### WORD ABOUT SAFETY

Beginning in June 2012, the above **WARNING** signage has been placed on all **nyb** fans, as specified by ISO and recommended by the European Union. Air moving equipment involves electrical wiring, moving parts, sound, and air velocity or pressure which can create safety hazards if the equipment is not properly installed, operated and maintained. To minimize this danger, follow these instructions as well as the additional instructions and warnings on the equipment itself.

All installers, operators and maintenance personnel should study AMCA Publication 410, "Recommended Safety Practices for Air Moving Devices", which is included as part of every shipment. Additional copies can be obtained by writing to New York Blower Company, 7660 Quincy St., Willowbrook, IL 60527.

### ELECTRICAL DISCONNECTS

Every motor driven fan should have an independent disconnect switch to isolate the unit from the electrical supply. It should be near the fan and must be capable of being locked by maintenance personnel while servicing the unit, in accordance with OSHA procedures.

### MOVING PARTS

All moving parts must have guards to protect personnel. Safety requirements vary, so the number and type of guards needed to meet company, local and OSHA standards must be determined and specified by the user. Never start a fan without having all safety guards installed. Check regularly for damaged or missing guards and do not operate any fan with guards removed. Fans can also become dangerous because of potential "windmilling", even though all electrical power is disconnected. Always block the rotating assembly before working on any moving parts.



**Danger:** Do Not Enter/Confined Space

### ACCESS DOORS

The above DANGER decal is placed on all **nyb** cleanout doors. These doors, as well as access doors to the duct system, should never be opened while the fan is in operation. Serious injury could result from the effects of air pressure or suction.

Quick-opening doors must have the door handle bolts securely tightened to prevent accidental or unauthorized opening. Bolted doors must be tightened for the same reason.

### RECEIVING AND INSPECTION

The fan and accessories should be inspected on receipt for any shipping damage. Turn the wheel by hand to see that it rotates freely and does not bind. If dampers or shutters are provided, check these accessories for free operation of all moving parts.

F.O.B. factory shipping terms require that the receiver be responsible for inspecting the equipment upon arrival. Note damage or shortages on the Bill of Lading and file any claims for damage or loss in transit. **nyb** will assist the customer as much as possible; however, claims must be originated at the point of delivery.

## HANDLING

Fans should be lifted by the base, mounting supports, or lifting eyes/lugs only. Never lift a fan by the wheel, shaft, motor, motor bracket, housing inlet, outlet, or any fan part not designed for lifting. A spreader should be used to avoid damage.

On direct drive Arrangement 7 or 8 fans, lifting holes are provided in the motor base to assist in handling the fan assembly. These lifting holes should be used in conjunction with the lifting eyes/lugs when lifting and positioning the fan onto its foundation. A heavy round steel bar or appropriate fixture can be passed through the lifting holes to simplify attachment of the lifting device. Be sure to follow all local safety codes when moving heavy equipment.

## STORAGE

Whenever possible, fans and accessories should be stored in a clean, dry location to prevent rust and corrosion of steel components. If outdoor storage is necessary, protection should be provided. Cover the inlet and outlet to prevent the accumulation of dirt and moisture in the housing. Cover motors with water-proof material. Remove any fan and motor drain plugs to minimize moisture buildup. Refer to motor manufacturer's IM manual for further motor storage instructions.

Any stored bearing can be damaged by condensation caused by temperature variations. Therefore, **nyb** fan bearings are filled with grease at the factory to exclude air and moisture. Such protection is adequate for shipment and subsequent immediate installation and operation.

For long term or outdoor storage, mounted bearings should be immediately regreased and wrapped with plastic for protection. Split housed bearings may require additional grease to completely fill the bearing housing cavity. **Rotate the fan wheel and motor shaft by hand at least every two weeks to redistribute grease on internal bearing parts.** Each month the fan and motor bearings should be purged with new grease to remove condensation, since even a filled bearing can accumulate moisture. Use caution when purging, as excessive pressure can damage the seals. Rotate the shaft while slowly adding grease.

For Belt-Driven units, belts should be slackened to prevent damage to shaft, belts, and bearings.

Check shutters for free operation and lubricate moving parts prior to storage. Inspect the stored unit periodically to ensure the above precautionary storage measures are still in tact.

Prior to start-up, split housed bearings should have excess grease removed such that the grease level is level with the bottom of the shaft.

## FAN INSTALLATION

**nyb** wheels are dynamically balanced when fabricated. Fully assembled fans are test run at operating speeds to check the entire assembly for conformance to **nyb** vibration limits. Nevertheless, all units must be adequately supported for smooth operation. **Ductwork or stacks should be independently supported as excess weight may distort the fan housing and cause contact between moving parts.** **nyb**

**recommends using flexible connections at the inlet and outlet to prevent vibration transmission from the fan to the system and vice versa.** Flexible connectors also eliminate loading issues stemming from thermal expansion in systems with high temperature air streams. Where vibration isolators are used, consult the **nyb** certified drawing for proper location and adjustment.

## Slab-Mounted Units

A correctly designed and level concrete foundation provides the best means of installing floor-mounted fans. The mass of the base must maintain the fan/driver alignment, absorb normal vibration, and resist lateral loads. The overall dimensions of the concrete base should extend at least six inches beyond the base of the fan. The weight of the slab should be approximately three times the weight of the total fan assembly weight, including the motor. The foundation requires firmly anchored fasteners such as the anchor bolts shown in Figure 1. Hammer-drilled expansion fasteners can be used in less demanding applications.

Move the fan to the mounting location and lower it over the anchor bolts, leveling and supporting the fan base with shims at each bolt hole location. Fasten the fan securely, ensuring that the fan base is not put into a bind when tightening anchor bolts. This may cause distortion that can be transferred to the bearing housings, causing excessive vibration and premature bearing failure. You should consider grouting in fans sized 40 and larger. When grout is used, shim the fan at least 3/4-inch from the concrete base. Do not rely on grout to support the fan structure. (See Figure 1.) When isolation is used, check the **nyb** certified drawing for installation instructions.

## Elevated Units

When an elevated or suspended structural steel platform is used, it must have sufficient bracing to support the unit load and prevent side sway. A poorly designed support structure can experience resonance triggered by the fan operating speed. The platform should be of welded construction to maintain permanent alignment of all members.

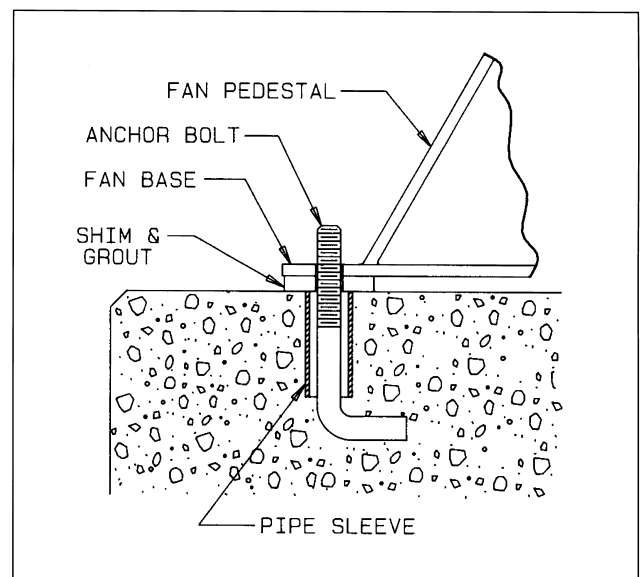

Figure 1

## V-BELT DRIVE

### Installation

1. Remove all foreign material from the fan and motor shafts. Coat shafts with machine oil for easier mounting. Mount the belt guard backplate at this time if partial installation is required prior to sheave mounting.
2. Mount sheaves on shafts after checking sheave bores and bushings for nicks or burrs. Avoid using force. If resistance is encountered, lightly polish the shaft with emery cloth until the sheave slides on freely. Tighten tapered bushing bolts sequentially so that equal torque is applied to each.
3. Adjust the motor on its base to a position closest to the fan shaft. Install belts by working each one over the sheave grooves until all are in position. Never pry the belts into place. On **nyb** packaged fans, sufficient motor adjustment is provided for easy installation of the proper size belts. **Warning: Do not rotate sheaves by grabbing belts by hand.**
4. Adjust sheaves and the motor shaft angle so that the sheave faces are in the same plane. Check this by placing a straightedge across the faces of the sheaves. Any gap between the edge and sheave faces indicates misalignment. Important: This method is only valid when the width of the surface between the belt edge and the sheave face is the same for both sheaves. When they are not equal, or when using adjustable-pitch sheaves, adjust so that all belts have approximately equal tension. Both shafts should be at right angles to the center belt.

### Belt Tensioning

1. Check belt tension with a tensioning gage and adjust using the motor slide base. Excess tension shortens bearing life while insufficient tension shortens belt life, this can reduce fan performance and may cause vibration. The lowest allowable tension is that which prevents slippage under full load. Belts may slip during start-up, but slipping should stop as soon as the fan reaches full speed. For more precise tensioning methods, consult the drive manufacturer's literature.
2. Recheck setscrews, rotate the drive by hand and check for rubbing, then complete the installation of the belt guard
3. Belts tend to stretch somewhat after installation. Recheck tension after several days of operation. Check sheave alignment as well as setscrew and/or bushing bolt tightness.

## COUPLING

Coupling alignment should be checked after permanent installation and prior to start up. Alignment is set at the factory, but shipping, handling, and installation can cause misalignment. Also check for proper coupling lubrication. For details on lubrication and for alignment tolerances on the particular coupling supplied, see the manufacturer's installation and maintenance supplement in the shipping envelope

### Installation

Most **nyb** fans are shipped with the coupling installed. In cases where the drive is assembled after shipping, install the coupling as follows:

1. It is recommended to wait until the fan is permanently installed before beginning the coupling alignment process in order to prevent possible misalignment during fan installation.
2. Remove all foreign material from fan and motor shafts and

coat with machine oil for easy mounting of coupling halves.

3. Mount the coupling halves on each shaft, setting the gap between the faces specified by the manufacturer. Avoid using force. If mounting difficulty is encountered, lightly polish the shaft with emery cloth until the halves slide on freely.

### Alignment

1. Align the coupling to within the manufacturer's limits for parallel and angular misalignment (see Figure 2). A dial indicator or laser can also be used for alignment where greater precision is desired. Adjustments should be made by moving the motor to change shaft angle, and by the use of foot shims to change motor shaft height. Do not move the fan shaft or bearing.
2. When correctly aligned, install the flexible element and tighten all fasteners in the coupling and motor base. Lubricate the coupling if necessary.
3. Recheck alignment and gap after a short period of operation, and recheck the tightness of all fasteners in the coupling assembly.

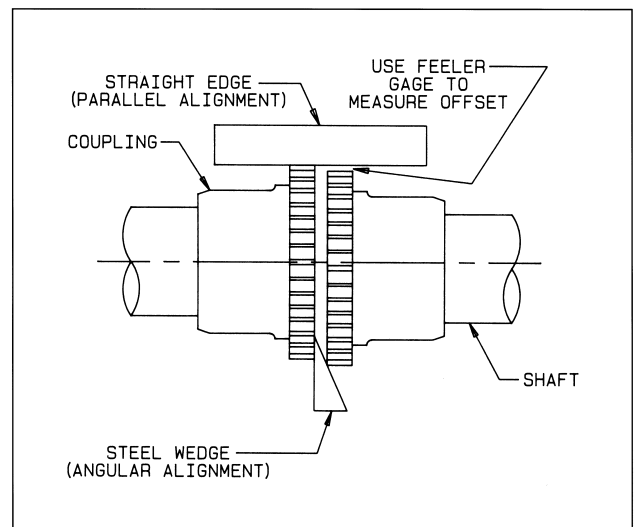

Figure 2

### START-UP

A start-up checklist is available on **nyb**'s Maintenance manuals page under the support tools menu, [Click Here](#). Safe operation and maintenance includes the selection and use of appropriate safety accessories for the specific installation. This is the responsibility of the system designer and requires consideration of equipment location and accessibility as well as adjacent components. All safety accessories must be installed properly prior to start-up.

Safe operating speed is a function of system temperature and wheel design. Do not under any circumstances exceed the maximum safe fan speed published in your **nyb** certified drawing package, which is available from your **nyb** field sales representative.

### Procedure

1. If the drive components are not supplied by **nyb**, verify with the manufacturer that the starting torque is adequate for the speed and inertia of the fan.

2. Inspect the installation prior to starting the fan. Check for any loose items or debris that could be drawn into the fan or dislodged by the fan discharge. Check the interior of the fan as well. Turn the wheel by hand to check for binding.
3. Check drive installation and belt tension.
4. Check the tightness of all setscrews, nuts and bolts. Ensure that anchor bolts are also properly torqued. When furnished, tighten hub setscrews with the wheel oriented so that the setscrew is positioned underneath the shaft.
5. Install all remaining safety devices and guards. Verify that the supply voltage is correct and wire the motor. "Bump" the starter to check for proper wheel rotation.
6. Check to ensure that neither the fan nor motor shaft are rotating.
7. "Bump" the starter to check for proper wheel rotation.
8. Use extreme caution when testing the fan with ducting disconnected. Apply power and check for unusual sounds or excessive vibration. If either exists, see the section on Common Fan Problems. To avoid motor overload, do not run the fan for more than a few seconds if ductwork is not fully installed. Without the ductwork attached, normal operating speed may not be obtained without motor overload. Once ductwork is attached, check for correct fan speed and complete installation. Ductwork and guards must be fully installed for safety.
9. All wheel, sheave, and coupling setscrews should be rechecked after a few minutes, eight hours and two weeks of operation (see Tables 1 & 2 for correct tightening torques).

**NOTE: Shut the fan down immediately if there is any sudden increase in fan vibration.**

**Table 1 - WHEEL SETSCREW TORQUES**

Setscrew Size Diameter (in.)	Carbon Steel Setscrew Torque*	
	lb.-in.	lb.-ft.
1/4	75	6.2
5/16	144	12
3/8	252	21
7/16	396	33
1/2	600	50
5/8	1164	97
3/4	2016	168
7/8	3204	267
1	4800	400

\* Stainless Steel setscrews are not hardened and should not be tightened to more than 1/2 the values shown.

**Table 2 – BEARING SETSCREW TORQUE, lb.-in.**

Setscrew Diameter	Manufacturer				
	Link-Belt	Sealmaster	SKF	McGill	Dodge
#10	40	--	35	35	--
1/4	90	65	50	85	--
5/16	185	125	165	165	160
3/8	325	230	290	290	275
7/16	460	350	350	--	--
1/2	680	500	620	--	600
5/8	1350	1100	1325	--	1200
3/4	2350	--	--	--	2000

**Note: Split pillow block bearing are fixed to the shaft with tapered sleeves and generally do not have setscrews.**

### Fan Shutoff for Fans with Elevated Airstream Temperatures (Greater than 200 °F)

High temperature, rotating equipment such as fans must be protected from "heat soaking". Fan wheels must be rotating whenever the airstream temperature is above 200°F. to prevent the shaft from "sagging" causing a permanent bend in the shaft. After the airstream temperature has fallen below 200°F, the fan can be shutdown. Start-up and shut down procedures are required to prevent this. If a power failure occurs, rotate the shaft manually if necessary.

If a shaft is bent due to heat soaking or binding a sudden increase in fan vibration will occur. The shaft will need to be removed, checked for straightness and straightened or replaced.

### FAN MAINTENANCE

nyb fans are manufactured to high standards with quality materials and components. Proper maintenance will ensure a long and trouble-free service life. **Do not attempt any maintenance on a fan unless the electrical supply has been completely disconnected and locked out.** In many cases, a fan can windmill despite removal of all electrical power. The rotating assembly should be blocked securely before attempting maintenance of any kind.

The key to good fan maintenance is regular and systematic inspection of all fan parts. Inspection frequency is determined by the severity of the application and local conditions. Strict adherence to an inspection schedule is essential.

Regular fan maintenance should include the following:

1. Check the fan wheel for any wear or corrosion, as either can cause catastrophic failures. Check also for the build-up of material, which can cause unbalance resulting in vibration, bearing wear and serious safety hazards. Clean or replace the wheel as required.
  2. Check the V-belt drive for proper alignment and tension (see section on V-belt drives). If belts are worn, replace them as a set, matched to within manufacturer's tolerances. Lubricate the coupling of direct-drive units and check for alignment (see section on couplings).
  3. Lubricate the bearings, but do not over lubricate (see the bearing section for detailed specifications).
  4. Ceramic-felt shaft seals require no maintenance, although worn seals should be replaced. When lip-type shaft seals are provided, lubricate them with "NEVER-SEEZ" or other anti-seize compound. Schedule in accordance with the bearing lubrication table on page 5.
- WARNING: Do not remove or loosen the fan hub from the fan wheel. Removing or loosening the fan hub from the fan wheel will cause imbalance and void the warranty.**
5. During any routine maintenance, all setscrews and bolts should be checked for tightness. See the corresponding table for correct torques.
  6. When installing a new wheel or cone, the proper wheel-to-inlet cone clearance must be maintained (see Figure 3 for correct full-width wheel dimensions) (Dims. for narrow width wheels will vary)

**FULL WIDTH WHEEL CONE CLEARANCES  
(contact nyb for partial width dimensions)**

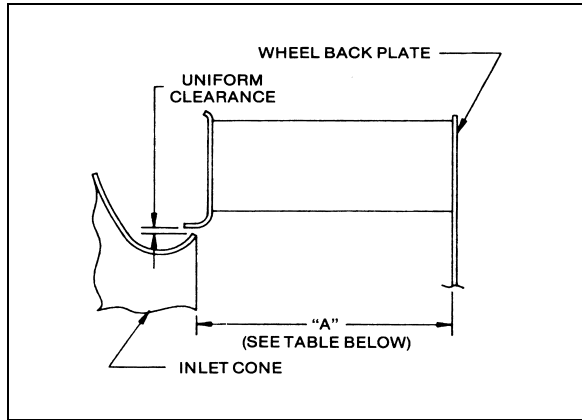

**Figure 3**

Fan Size		"A" Dimension [inches]					
AcF/PLR, BC, EcF Plenum	AF, HPBC, RTS	AcF/PLR	AF	BC	RTS	HPBC	EcF Plenum
10	--	3 1/2	--	--	--	--	--
12	--	4 1/2	--	--	--	--	4 5/8
15	--	5 1/2	--	--	--	--	5 7/8
18	24	7	7 1/4	--	--	4 7/8	7 1/2
22	27	8 1/4	8	--	6 7/8	5 3/8	8 7/8
24	30	9 1/4	9	9 3/16	7 5/8	6	10 1/8
27	33	10 1/8	9 3/4	10 1/8	8 3/8	6 9/16	10 7/8
30	36	11 1/4	10 7/8	11 3/16	9 3/8	7 1/4	12
33	40	12 1/4	12	12 5/16	10 1/2	8	13 1/8
36	44	13 3/8	13 1/4	13 5/8	11 5/8	8 7/8	14 1/2
40	49	14 3/4	14 5/8	15 1/16	12 7/8	9 3/4	15 7/8
44	54	16 1/4	16 1/8	16 5/8	14 1/4	10 13/16	17 3/8
49	60	17 7/8	17 3/4	18 5/16	15 3/4	11 15/16	19 1/4
54	66	19 3/4	19 5/8	20 1/4	17 3/8	13 1/8	21 1/8
60	73	21 3/4	21 3/4	22 3/8	19 1/4	14 9/16	23 1/4
66	80	24	24	24 5/8	20 7/8	16 1/16	25 5/8
73	--	26 1/2	27 1/4	27 1/4	23 1/4	17 3/4	27 5/8
80	--	28 3/4	30 1/8	30 1/8	--	--	--
89	--	31 5/8	33 1/4	33 1/4	--	--	--

**WHEEL BALANCE**

Airstreams containing particulate or chemicals can cause abrasion or corrosion of the fan parts. This wear is often uneven and can lead to significant wheel imbalance over time. When such wear is discovered, a decision must be made as to whether to rebalance or replace the wheel.

The soundness of all parts should be determined if the original thickness of components is reduced. Be sure there is no hidden structural damage. The airstream components should also be cleaned to remove any build-up of foreign material. Specialized equipment can be used to rebalance a cleaned wheel that is considered structurally sound.

Balance weights should be rigidly attached at a point that will not interfere with the housing nor disrupt airflow. Remember that centrifugal forces can be extremely high at the outer radius of a fan wheel. Welding is the preferred method of balance weight attachment. Be sure to ground the welder directly to the fan wheel. Otherwise, the welding current could pass through the fan bearings and damage them.

**Storage**

Any stored bearing can be damaged by condensation caused by temperature variations. Therefore, **nyb** fan bearings are filled with grease at the factory to exclude air and moisture. Such protection is adequate for shipment and subsequent immediate installation and operation.

For long term or outdoor storage, mounted bearings should be immediately regreased and wrapped for protection. Split housed bearings may require additional grease to completely fill the bearing housing cavity. **Rotate the fan wheel and motor shaft by hand at least every two weeks to redistribute grease on internal bearing parts.** Each month the fan and motor bearings should be purged with new grease to remove condensation, since even a filled bearing can accumulate moisture. Use caution when purging, as excessive pressure can damage the seals. Rotate the shaft while slowly adding grease.

**Operation**

Check the setscrew torque before start-up (see corresponding table for correct values). Since bearings are completely filled with grease at the factory, they may run at an elevated temperature during initial operation. Surface temperatures may reach 180°F. and grease may bleed from the bearing seals. This is normal and no attempt should be made to replace lost grease. Bearing surface temperatures will decrease when the internal grease quantity reaches a normal operating level. Relubrication should follow the recommended schedule.

**Lubrication**

Use the table for relubrication scheduling according to operating speed and shaft diameter. Fan bearings should be lubricated with a premium quality lithium-based grease conforming to NLGI Grade 2. Examples are:

- Mobil - Mobilgrease XHP 222      Exxon - Ronex MP
- Mobil - Unirex N2                      Shell - Gadus S2 V220
- Mobil - SHC100

These greases are for fan bearing surface temperatures of 40°F. to 180°F. For surface temperatures of 181°F. to 230°F. use Mobilith SHC220. Do not use "high temperature" greases, as many are not formulated to be compatible with fan bearings.

Add grease to the fan bearings while running the fan or rotating the shaft by hand. Be sure all guards are in place if lubrication is performed while the fan is operating. Add just enough grease to cause a slight purging at the seals except on split pillowblocks. Completely filled fan bearings will run hotter until a sufficient amount of grease is purged out of the seals.

Split pillowblock bearings (Link-Belt P-LB6800 & P-LB6900, SKF SAF 22500, Dodge SAF-XT) should be cleaned and repacked at approximately every eighth lubrication interval. This requires removal of the bearing cap. Clean out old grease and repack the bearing with fresh grease. Pack the bearing fully and fill the housing reservoir to the bottom of the shaft on both sides of the bearing. Replace the bearing cap, being careful not to mix caps, as they are not interchangeable from one bearing to another. **Do not over lubricate split pillowblock bearings.**

Refer to your motor manufacturer's installation and maintenance manual for motor bearing lubrication information.

**BEARING LUBRICATION INTERVAL (months)**

Shaft	RPM									
	1-500	501-1000	1001-1500	1501-2000	2001-2500	2501-3000	3001-3500	3501-4000	4001-4500	4501-5000
5/8 Thru 1	6	6	6	5 2	6 2	6 2	4 1	4 1	4 1	2 1
13/16 thru 1 7/16	6	6 2.5	6 1.75	4 1.25	4 1	4 1/2	2 1/2	2 1/2	2 1/2	1 1/2
1 11/16 thru 1 15/16	6	6 2.5	4-6 1.5	4 1.14	4 3/4	2 1/2	2 1/2	2 1/2	1 1/2	1
2 3/16	6	6 2.25	4-6 1.25	4 3/4	2 1/2	2 1/2	1 1/2	1 1/2	1	
2 7/16	6	4-6 2	4-6 1	4 3/4	2 1/2	2 1/2	1 1/2	1	1	
2 11/16 & 2 15/16	5	4 2	2-4 1	2 3/4	2 1/2	1 1/2	1	1	1	
3 7/16 thru 4 3/16	4	4 2	2-4 1	1 1/2	2	1	1	1		
4 7/16	4	4 1	2 1/2	1						
4 15/16	4	2 4 1	2 1/2							
5 7/16	6	4	2							
6	6	4								

**Ball Bearings & Split Pillowblock Spherical Roller Bearings**

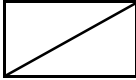

**Non-Split Pillowblock Spherical Roller Bearings**

- Note:**
1. These are general recommendations only; specific manufacturer's recommendations may vary slightly.
  2. Assumes clean environment, -20°F. to 120°F.
    - a. Consult The New York Blower Company for operation below -20°F. ambient.
  3. Assumes horizontal mounting configuration. For vertically mounted applications, lubricate twice as frequently.
  - b. Ambient temperature greater than 120°F. will shorten bearing life.
  - c. Under extremely dirty conditions, lubricate more frequently.

---

**Government Warnings**

Disposal of material should be made in accordance to local government regulations.

California Prop 65 – **WARNING:** This product contains a chemical known to the state of California to cause cancer and/or birth defects or other reproductive harm.

---

## COMMON FAN PROBLEMS

### Excessive Vibration

A common complaint regarding industrial fans is "excessive vibration". **nyb** is careful to ensure that each unit is precisely balanced prior to shipment; however, there are many other causes of vibration including:

1. Loose mounting bolts, setscrews, bearings or couplings.
2. Misalignment or excessive wear of couplings or bearings.
3. Misaligned or unbalanced motor.
4. Bent shaft due to mishandling or material impact.
5. Accumulation of foreign material on the wheel.
6. Excessive wear or erosion of the wheel.
7. Excessive system pressure or restriction of airflow due to closed dampers.
8. Inadequate structural support, mounting procedures or materials.
9. Externally transmitted vibration.

### Inadequate Performance

1. Incorrect testing procedures or calculations.
2. Fan running too slowly.
3. Fan wheel rotating in wrong direction or installed backwards on shaft.
4. Wheel not properly centered relative to inlet cone.
5. Damaged or incorrectly installed cut off sheet or diverter.
6. Poor system design, closed dampers, air leaks, clogged filters, or coils.
7. Obstructions or sharp elbows near inlets.
8. Sharp deflection of airstream at fan outlet.

### Excessive Noise

1. Fan operating near "stall" due to incorrect system design or installation.
2. Vibration originating elsewhere in the system.
3. System resonance or pulsation.
4. Improper location or orientation of fan intake and discharge.
5. Inadequate or faulty design of supporting structures.
6. Nearby sound reflecting surfaces.
7. Loose accessories or components.
8. Loose drive belts.
9. Worn bearings.

### Premature Component Failure

1. Prolonged or major vibration.
2. Inadequate or improper maintenance.

3. Abrasive or corrosive elements in the airstream or surrounding environment.
4. Misalignment or physical damage to rotating components or bearings.
5. Bearing failure from incorrect or contaminated lubricant or grounding through the bearings while arc welding.
6. Excessive fan speed.
7. Extreme ambient or airstream temperatures.
8. Improper belt tension.
9. Improper tightening of wheel setscrews.

## REPLACEMENT PARTS

It is recommended that only factory-supplied replacement parts be used. **nyb** fan parts are built to be fully compatible with the original fan, using specific alloys and tolerances. These parts carry a standard **nyb** warranty.

When ordering replacement parts, specify the part name, **nyb** shop and sequence number, fan size, type, rotation (viewed from drive end), arrangement and bearing size or bore. Most of this information is on the metal nameplate attached to the fan base.

For assistance in selecting replacement parts, contact your local **nyb** representative or visit: <http://www.nyb.com/replacement-parts-form/>

Example 1 (Prior to 2013):

Part required: Wheel  
Shop/control number: B-10106-100  
Fan description: 33" PLR  
Clockwise rotation  
Arrangement: 1  
Bearing: Link-Belt P335, 2-3/16 Bore

Example 2 (After to 2013):

Part required: Wheel  
Shop number: 2013-XXXXX Wheel  
Size & Type: 36 ACF  
Year of Manufacture: 2013  
Fan Description: ACF SW Fan Class 3 Arr-9

Suggested replacement parts include:

Wheel	Component parts: Damper
Shaft	Motor
Bearings	Coupling
Shaft Seal	Sheaves
Inlet Cone	V-Belts

## LIMITED PRODUCT WARRANTY

All products are warranted by **nyb** to be free from defects in materials and workmanship for a period of one (1) year after shipment from its plant, provided buyer demonstrates to satisfaction of **nyb** that the product was properly installed and maintained in accordance with **nyb's** instructions and recommendations and that it was used under normal operating conditions.

This warranty is limited to the replacing and/or repairing by **nyb** of any part or parts which have been returned to **nyb** with **nyb's** written authorization and which in **nyb's** opinion are defective. Parts not manufactured by **nyb** but installed by **nyb** in equipment sold to the buyer shall carry the original manufacturer's warranty only. All transportation charges and any and all sales and use taxes, duties, imports or excises for such part or parts shall be paid for by the buyer. **nyb** shall have the sole right to determine whether defective parts shall be repaired or replaced.

This warranty does not cover any customer labor charges for replacement of parts, adjustments or repairs, or any other work unless such charges shall be assumed or authorized in advance, in writing, by **nyb**.

This warranty does not cover any product which, in the judgement of **nyb**, has been subject to misuse or neglect, or which has been repaired or altered outside **nyb's** plant in any way which may have impaired its safety, operation or efficiency, or any product which has been subject to accident.

This warranty shall be null and void if any part not manufactured or supplied by **nyb** for use in any of its products shall have been substituted and used in place of a part manufactured or supplied by **nyb** for such use.

There are no warranties, other than those appearing on the acknowledgement form **INCLUDING NO WARRANTY OF MERCHANTABILITY OR FITNESS FOR A PARTICULAR PURPOSE**, given in connection with the sale of the goods sold hereunder. The buyer agrees that his sole and exclusive remedy, and the limit of **nyb's** liability for loss from any cause whatsoever, shall be the purchase price of the goods sold hereunder for which a claim is made.

WHEEL ROTATION AS VIEWED FROM DRIVE SIDE  
(COUNTERCLOCKWISE)

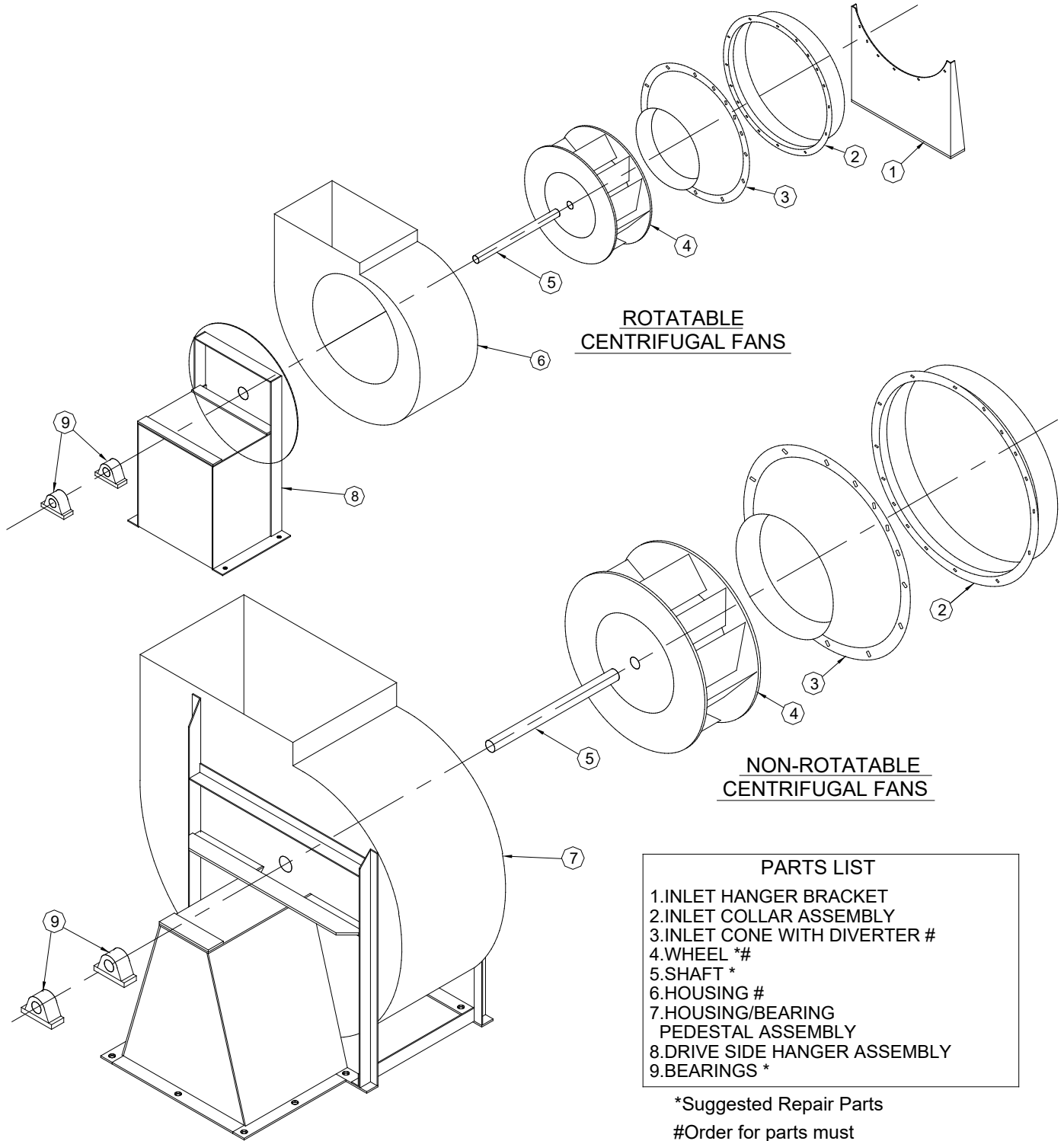
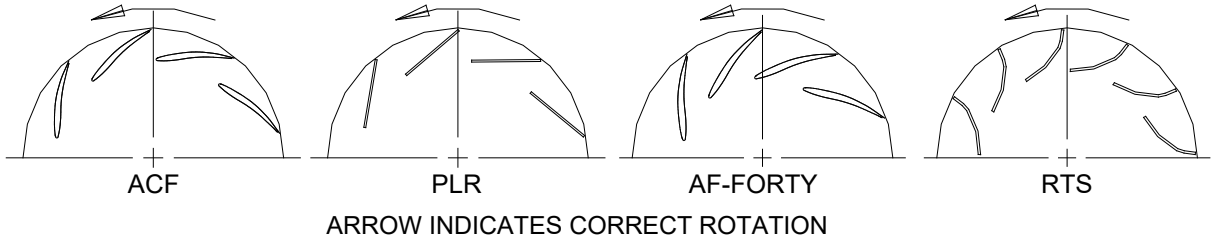

\*Suggested Repair Parts

#Order for parts must specify rotation.

When ordering replacement parts supply nyb shop number from nameplate and complete description of parts required.